

**EN**



**ES**



**FR**



**DE**



**IT**



**PT**



**NL**



**RU**



**CZ**





**AdBlue/DEF module  
cleaning kit**

User manual

[jaltest.com](http://jaltest.com)

**cojali**  
INNOVATION & TECHNOLOGY



Rev. 01



## AdBlue/DEF module cleaning kit

User manual



# Index

Index	3
General information	4
1.1 PRODUCT DESCRIPTION	4
1.2 CONTENT	4
1.3 APPLICATION	4
1.4 SAFETY PRECAUTIONS	5
Procedure	6
2.1 ADBLUE/DEF EMITEC SYSTEM (NONOX)	6
2.1.1 PREVIOUS STEPS	6
2.1.2 CLEANING OF THE ADBLUE/DEF OUTLET CIRCUIT	7
2.1.3 CLEANING FROM THE ADBLUE/DEF INLET CIRCUIT TO THE MODULE	9
2.1.4 SUBSEQUENT STEPS	10
2.2 ADBLUE/DEF EMITEC SYSTEM (CUMMINS ENGINE)	11
2.2.1 PREVIOUS STEPS	11
2.2.2 CLEANING OF THE ADBLUE/DEF OUTLET CIRCUIT	11
2.2.3 CLEANING FROM THE ADBLUE/DEF INLET CIRCUIT TO THE MODULE	13
2.2.4 SUBSEQUENT STEPS	14
2.3 ALBONAIR ADBLUE/DEF SYSTEM	14
2.3.1 PREVIOUS STEPS	14
2.3.2 CLEANING OF THE ADBLUE/DEF CIRCUIT	16
2.3.3 SUBSEQUENT STEPS	18
2.4 BOSCH DENOXTRONIC 2.2 AND DENOXTRONIC 6-HD ADBLUE/DEF SYSTEM	18
2.4.1 PREVIOUS STEPS	18
2.4.2 ADBLUE/DEF CIRCUIT CLEANING	19
2.4.3 SUBSEQUENT STEPS	21

## Easy navigation

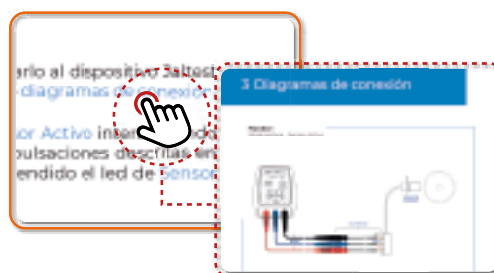
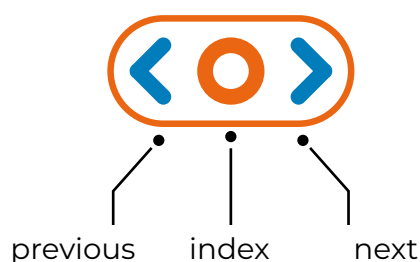

Faster access to any content you need by clicking

# 1 General information

## 1.1 PRODUCT DESCRIPTION

Equipment for cleaning the crystallised AdBlue/DEF residues in the dosing module, the injector line and the injector.

## 1.2 CONTENT

### 1.3. Hoses.

**2a.** Tank 0.4l.

**2b.** Tank 1.5l.

**4.** Adapter to connect the compressed air intake to the AdBlue/DEF module. (4a and 4b).

**5.** Adapter to connect the compressed air supply from the vehicle to the AdBlue/DEF module.

**6.** Filling bottle.

**7.** Adapter for the AdBlue/DEF inlet to the module.

**8.** Adapter for AdBlue/DEF return to the module.

**9.** 3/8" adapters for the connection of the inlet and return pipes to the AdBlue/DEF tank.

**10.** 5/16" adapters for the connection of the inlet and return pipes to the AdBlue/DEF tank.

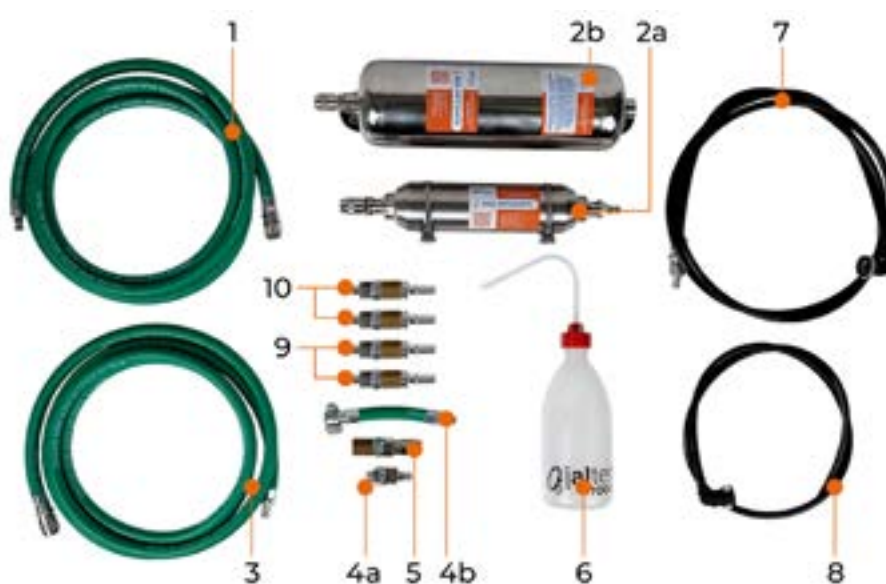

## 1.3 APPLICATION

- NoNOX system (MAN TGL, TGM, TGS, TGX and Euro 6 buses with AdBlue Emitec system).
- AdBlue/DEF Emitec system in vehicles with Cummins engine.
- Albonair AdBlue/DEF system (VOLVO, RENAULT UD Trucks and other Euro 6 vehicles).
- Bosch Denoxtronic 2.2 and Denoxtronic 6-HD AdBlue/DEF system (DAF, IVECO, MAN, other Euro 6 vehicles, agricultural equipment, OHW equipment, etc).

## 1.4 SAFETY PRECAUTIONS

The following safety precautions must be taken into account in order to prevent accidents and/or injuries:

- Place the vehicle on a flat surface.
- Activate the parking brake.
- Place the gearshift level in neutral position.
- Avoid contact with parts that might remain too hot or that are in movement.
- Use proper workwear.



## 2 Procedure

### 2.1 ADBLUE/DEF EMITEC SYSTEM (NONOX)

#### 2.1.1 PREVIOUS STEPS

**a.** Carry out the AdBlue/DEF circuit draining test with the diagnostics tool.

**NoNOx system >> System checks “SYSTEM FILLING AND PURGE”**

**b.** Disassemble the upper, front and side protective plates.



**c.** Disassemble the plate supports.





**d.** Disassemble the AdBlue/DEF injector fixing and remove the injector.

- Disassemble clamp.
- Unscrew the fitting nut.
- Remove the AdBlue/DEF injector and screw it again in the fitting nut.
- Clean the AdBlue/DEF injector nozzle.



**Note:** for your comfort during the subsequent steps, disassemble the NOx sensor fixings.

**e.** Disassemble the AdBlue/DEF module protections.



## 2.1.2 CLEANING OF THE ADBLUE/DEF OUTLET CIRCUIT

**a.** Evacuate the pneumatic supply pressure for improved comfort when disconnecting or removing lines through which compressed air flows.

**b.** Disassemble the compressed air intake connection to the AdBlue/DEF module (1).

**Note:** if the vehicle has pressurised air in the circuit, when removing the connection, this compressed air will be lost.





1. Compressed air intake.
2. Electrical connector/Compressed air flow control valve.
3. Electrical connector / AdBlue/DEF pump heater.
4. AdBlue/DEF intake.
5. AdBlue/DEF and air exhaust/mixture.
6. AdBlue/DEF return.

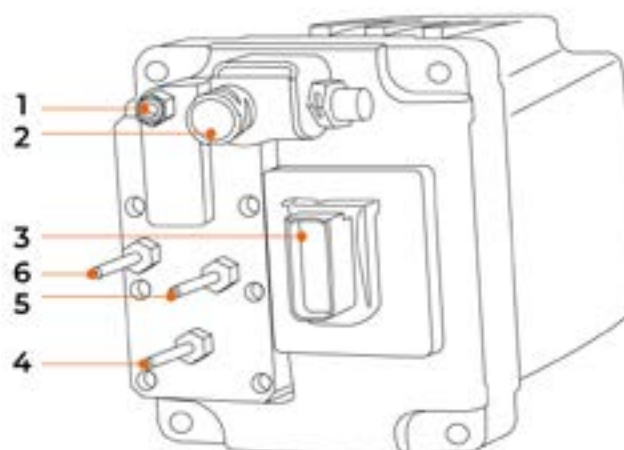

c. Connect the adapters “4” (4a or 4b as appropriate) and “5” in the compressed air intake of the AdBlue/DEF module (1) and in the compressed air exhaust of the vehicle. Next, join a hose (“1” and “3”) in each adapter but without connecting them to the tank “2” yet.

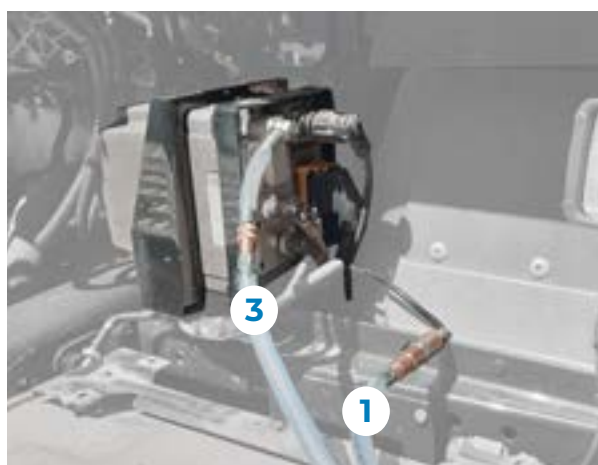

d. Fill tank “2a” with 250ml of hot distilled water (MAX. 60°C/140°F) from the upper part, using the filling bottle “6”.





e. Connect the hoses “1” and “3” to tank “2a”.



f. Start the engine and maintain it until the compressed air circuit is charged.

g. Perform the corresponding action as many times as necessary using the diagnostics tool until only compressed air is expelled through the injector nozzle. Use a container or measuring cylinder to collect 250ml of water approximately that will be expelled through the injector.

#### **NoNOx system >> System checks “AIR CIRCUIT CHECK”**

h. Carry out the pneumatic installation again prior to tests. Assembly the connection (1) of compressed air intake to the AdBlue/DEF module.

**Note:** if the compressed air circuit is not depressurised, then removing the connections, this compressed air will be lost.

## 2.1.3 CLEANING FROM THE ADBLUE/DEF INLET CIRCUIT TO THE MODULE

a. Start the engine and maintain it until the compressed air circuit is pressurised.

b. Disconnect the connections (4) and (6) from the AdBlue/DEF module.

c. Place a container or tube in the nozzle (6) to collect the amount of return liquid.

d. Connect the hose “7” with quick coupling of 3/8” to the AdBlue/DEF intake connector (4). Connect the other end to the quick connector at the bottom of the tank “2a”.

Previously, the tank must be empty and without the hoses of the previous test.

e. Fill tank “2a” with distilled water from the upper part (MAX. 60°C/140°F). Take into account that the amount entered will be approximately the one that is dosed.



**f.** Carry out the average dosage check. Use a container or measuring cylinder to collect the water to be dosed through the injector.

### **NoNOx system >> System checks >> ADBLUE/DEF DOSING >> “MEDIUM DOSING”**



## 2.1.4 SUBSEQUENT STEPS

- a.** Check that there are no errors memorised in the Control Unit.
- b.** Disassemble the AdBlue/DEF module cleaning equipment and rinse all components including the tank with hot water.
- c.** Connect the AdBlue/DEF module connections and check the tightness of both the module and the connections.
- d.** Assemble the plastic protections of the AdBlue/DEF module.
- e.** Assemble the protective plates.



## 2.2 ADBLUE/DEF EMITEC SYSTEM (CUMMINS ENGINE)

### 2.2.1 PREVIOUS STEPS

- a. Check the AdBlue/DEF fluid dosing system
- b. Turn off the ignition and disconnect the batteries
- c. Release the pressure from the AdBlue/DEF dosing system
- d. Remove the AdBlue/DEF injector

**Note:** place a suitable container at the end of the pipe



### 2.2.2 CLEANING OF THE ADBLUE/DEF OUTLET CIRCUIT

- a. Disconnect the AdBlue/DEF fluid return pipe **(6)**
- b. Disconnect the air supply line from the AdBlue/DEF dosing module **(1)**

- 1.** Compressed air intake.
- 2.** Electrical connector/Compressed air flow control valve.
- 3.** Electrical connector / AdBlue/DEF pump heater.
- 4.** AdBlue/DEF intake.
- 5.** AdBlue/DEF and air exhaust/mixture.
- 6.** AdBlue/DEF return.

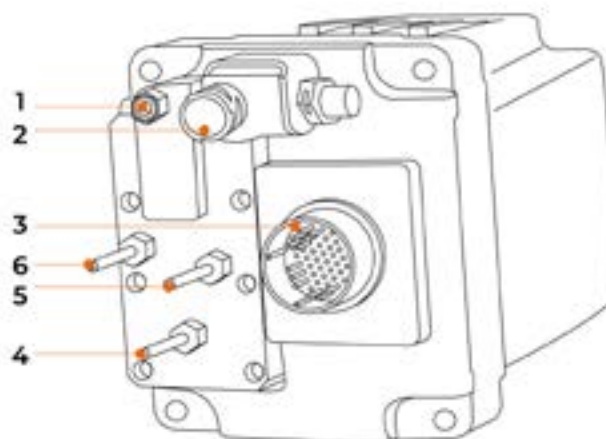



c. Connect the adapters “4” (4a or 4b as appropriate) and “5” in the compressed air intake of the AdBlue/DEF module (1) and in the compressed air exhaust of the vehicle. Next, join a hose (“1” y “3”) in each adapter but without connecting them to the tank “2a” yet.



d. Fill tank “2a” with 250ml of hot distilled water (MAX. 60°C/140°F) from the upper part, using the filling bottle “6”.



e. Connect the hoses “1” and “3” to tank “2a”

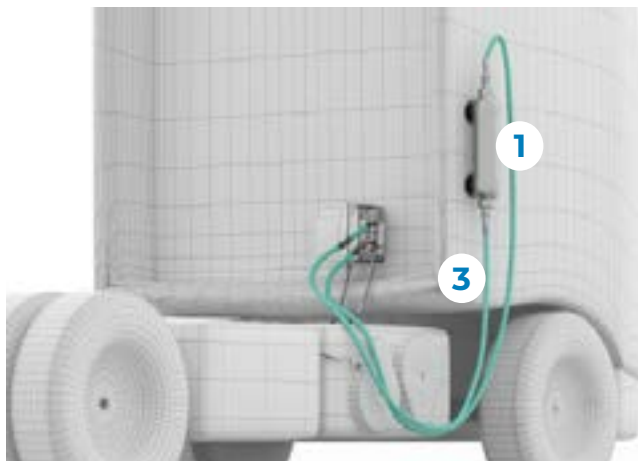



**f.** Start the engine

**g.** Perform the corresponding action as many times as necessary using the diagnostics tool until only compressed air is expelled through the injector nozzle. Use a container or measuring cylinder to collect 250ml of water approximately that will be expelled through the injector.

### **Actuate components >> “SOLENOID VALVE OF THE ADBLUE/DEF DOSING PUMP”**

**Note:** in this case, the action indicated serves only to ensure the proper cleaning of the AdBlue/DEF circuit.

**h.** Connect again all the elements previously disconnected.

## 2.2.3 CLEANING FROM THE ADBLUE/DEF INLET CIRCUIT TO THE MODULE

**a.** Disconnect the AdBlue/DEF supply pipe from the dosing module **(4)**.

**b.** Disconnect the AdBlue/DEF fluid return pipe **(6)**.

**c.** Place a container or tube in the nozzle **(6)** to collect the amount of return liquid.

**d.** Connect hose **“7”** with quick coupling of 3/8” to the AdBlue/DEF intake connector **(4)**.



**e.** Connect the hose to tank **“2a”**.

Previously, the tank must be empty and without the hoses of the previous test.





- f.** Fill tank “2a” with 250ml of hot distilled water (MAX. 60°C/140°F) from the upper part.
- g.** Start the engine
- h.** Perform the corresponding action with the diagnostics tool and assess the result. Use a container or measuring cylinder to collect the water that will be dosed by the injector. If the water is not drained completely, repeat the action.

### **System checks >> “ADBLUE/DEF PUMP”**

**Note:** in this case, the action indicated serves only to ensure the proper cleaning of the AdBlue/DEF circuit.

- i.** Connect again all the elements previously disconnected.

## 2.2.4 SUBSEQUENT STEPS

- a.** Check that there are no errors memorised in the Control Unit.
- b.** Disassemble the AdBlue/DEF module cleaning equipment and rinse all components with hot water, including the tank.
- c.** Assemble the AdBlue/DEF module connections and check the sealing of both the module and the connections.

## 2.3 ALBONAIR ADBLUE/DEF SYSTEM

### 2.3.1 PREVIOUS STEPS

- a.** Carry out the AdBlue/DEF circuit purge test with the diagnostics tool.

### **ACM system >> System checks >> “ADBLUE/DEF CIRCUIT PURGE”**

- b.** Disassemble the protective plates.





For greater comfort during the process, disassemble also the support of the side plate.



**c.** Disassemble the Adblue/DEF injector fixing and remove the injector.



**d.** Place a container under the injector nozzle.







## 2.3.2 CLEANING OF THE ADBLUE/DEF CIRCUIT

a. Disassemble the AdBlue/DEF intake connection to the module **(3)**.

**Note:** Clean the remaining AdBlue/DEF that might fall after the disconnection.

- A.** AdBlue/DEF pump.
- B.** Heating valve of the AdBlue/DEF tank.
- C.** AdBlue/DEF temperature sensor / Air control valve.
- D.** Air pressure sensor.
- E.** AdBlue/DEF pressure sensor.

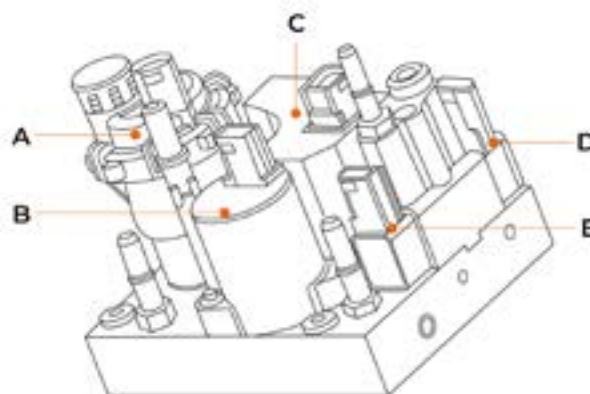

- 1.** Coolant intake.
- 2.** Compressed air intake.
- 3.** AdBlue/DEF intake.

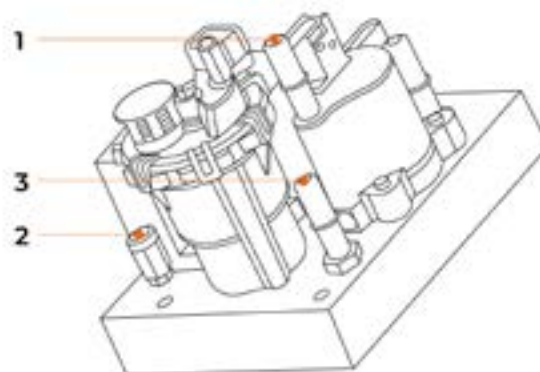

- 4.** Coolant outlet.
- 5.** Air outlet.
- 6.** AdBlue/DEF outlet.

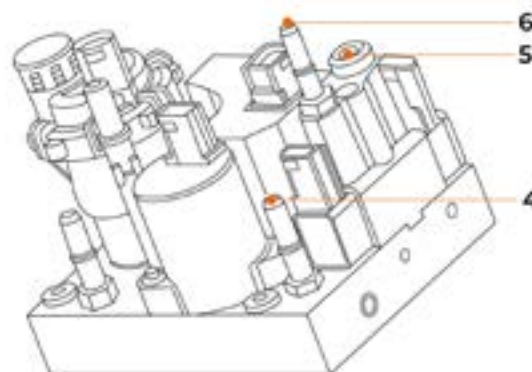



**b.** Connect hose “7” with quick coupling of 3/8” to the AdBlue/DEF intake connector (3).



**c.** Connect the other end of hose “7” to the quick connector at the bottom of tank “2”.

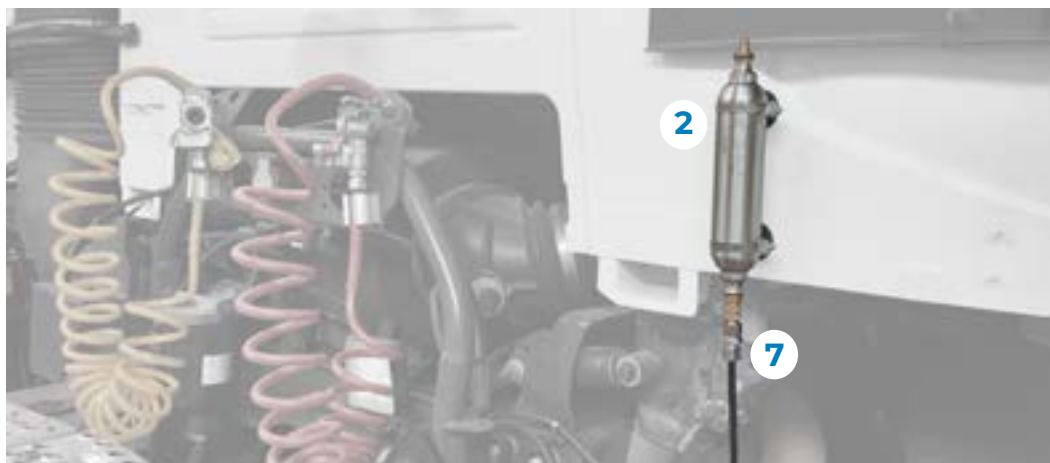

**d.** Fill tank “2” with approximately 200ml of hot distilled water (MAX. 60°C/140°F) from the upper part, using filling bottle “6”.





- e. Perform the cleaning check of the AdBlue/DEF module with the diagnostics tool.

### ACM system >> System checks >> “ADBLUE/DEF MODULE CLEANING”

**Note:** In order to ensure that the AdBlue/DEF circuit is not clogged and the system is operating correctly, the water volume dosed must be between the maximum and minimum values shown at the end of the action.

## 2.3.3 SUBSEQUENT STEPS

- a. Check that there are no errors memorised in the Control Unit.
- b. Disconnect the diagnostics tool and turn off the vehicle ignition.
- c. Disassemble the AdBlue/DEF module cleaning equipment and rinse all components including the tank with hot water.
- d. Assemble the AdBlue/DEF module connection and check the sealing of both the module and the connections.
- e. Assemble the AdBlue/DEF injector.
- f. Assemble the protective plates.

## 2.4 BOSCH DENOXTRONIC 2.2 AND DENOXTRONIC 6-HD ADBLUE/DEF SYSTEM

### 2.4.1 PREVIOUS STEPS

- a. Perform the AdBlue/DEF circuit purge.

**Note:** Turn off the ignition and wait 2 minutes before turning it on again.



**b.** Locate the AdBlue/DEF dosing module.

**Note:** The location depends on the vehicle.

**c.** Disassemble the protective plates if needed.

**d.** Disassemble the AdBlue/DEF injector fixing and remove the injector.

**Note:** The location depends on the vehicle.



**e.** Place a container under the injector nozzle.

## 2.4.2 ADBLUE/DEF CIRCUIT CLEANING

**a.** Disconnect the AdBlue/DEF supply pipe from the dosing module **(6)**.

**Note:** Clean the remaining AdBlue/DEF that might fall during the disconnection.

**b.** Disconnect the AdBlue/DEF fluid return pipe to the tank **(4)**.

- 1.** AdBlue/DEF outlet.
- 2.** Coolant outlet.
- 3.** Coolant intake.
- 4.** AdBlue/DEF return.
- 5.** Electrical connector.
- 6.** AdBlue/DEF intake.

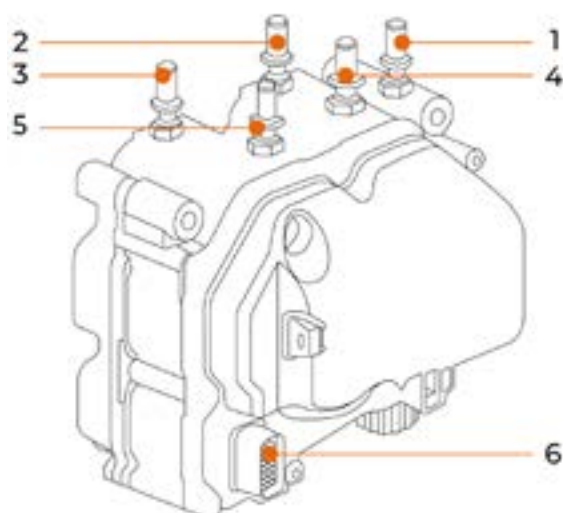

c. Connect hose “7” with quick coupling of 3/8” to the AdBlue/DEF intake connector (6).

d. Connect the adapter “8” to the AdBlue/DEF return connector (4) and place a container at the free end.

**Note:** During the test, and depending on the vehicle, the amount of return water might be up to 700ml approximately.



e. Connect the other end of hose “7” to the quick connector at the bottom of tank “2b”.

**Note:** Place the tank at a height above the inlet port of the AdBlue/DEF dosing module.



f. Fill tank “2b” with hot distilled water (60°C/140°F MAX.) from the upper part, using the filling bottle “6”.



- g.** Perform the action for the AdBlue/DEF module cleaning with the diagnostics tool.

### **Maintenance >> “ADBLUE/DEF MODULE CLEANING”**

**Note:** In order to ensure that the AdBlue/DEF circuit is not clogged and the system is operating correctly, the water volume dosed must be between the maximum and minimum values shown at the end of the action.

## 2.4.3 SUBSEQUENT STEPS

- a.** Check that there are no errors memorised in the control unit.
- b.** Disconnect hose “7” from the bottom of tank “2b”.
- c.** Disconnect the diagnostics tool and turn off the vehicle ignition.

**Important:** The system must automatically eject the remaining water from the pipes before continuing with the next step.

- d.** Disassemble the AdBlue/DEF module cleaning equipment and rinse all components including the tank with hot water.
- e.** Assemble all the components disassembled in previous steps.

# ●.cojali

Jaltest.com  
cojali.com

2023 V.1 EN



Local Distributor



**Kit para limpieza de módulo  
de AdBlue/DEF**

Manual de usuario

[jaltest.com](http://jaltest.com)

**cojali**  
INNOVATION & TECHNOLOGY





Rev. 01



## Kit para limpieza de módulo de AdBlue/DEF

Manual de usuario

**cojali**

INNOVATION & TECHNOLOGY



# Índice

Índice	3
Información general	4
1.1 DESCRIPCIÓN DEL PRODUCTO	4
1.2 CONTENIDO	4
1.3 APLICACIÓN	4
1.4 PRECAUCIONES DE SEGURIDAD	5
Procedimiento	6
2.1 SISTEMA ADBLUE/DEF EMITEC (NONOX)	6
2.1.1 PASOS PREVIOS	6
2.1.2 LIMPIEZA DEL CIRCUITO DE SALIDA DE ADBLUE/DEF	7
2.1.3 LIMPIEZA DEL CIRCUITO DE ENTRADA DE ADBLUE/DEF AL MÓDULO	9
2.1.4 PASOS POSTERIORES	10
2.2 SISTEMA ADBLUE/DEF EMITEC (MOTOR CUMMINS)	11
2.2.1 PASOS PREVIOS	11
2.2.2 LIMPIEZA DEL CIRCUITO DE SALIDA DE ADBLUE/DEF	11
2.2.3 LIMPIEZA DEL CIRCUITO DE ENTRADA DE ADBLUE/DEF AL MÓDULO	13
2.2.4 PASOS POSTERIORES	14
2.3 SISTEMA ADBLUE/DEF ALBONAIR	14
2.3.1 PASOS PREVIOS	14
2.3.2 LIMPIEZA DEL CIRCUITO DE ADBLUE/DEF	16
2.3.3 PASOS POSTERIORES	18
2.4 SISTEMA ADBLUE/DEF BOSCH DENOXTRONIC 2.2 Y DENOXTRONIC 6-HD	18
2.4.1 PASOS PREVIOS	18
2.4.2 LIMPIEZA DEL CIRCUITO DE ADBLUE/DEF	19
2.4.3 PASOS POSTERIORES	21

## Fácil navegación

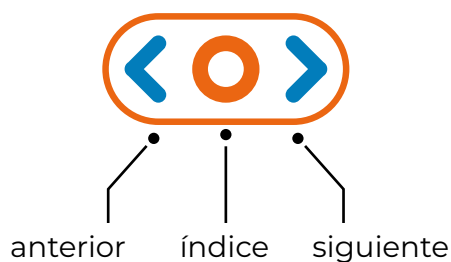

Accede más rápidamente al contenido que necesites haciendo clic

# 1 Información general

## 1.1 DESCRIPCIÓN DEL PRODUCTO

Equipo para realizar la limpieza de restos de AdBlue/DEF cristalizado en el módulo de dosificación, el conducto del inyector y el propio inyector.

## 1.2 CONTENIDO

**1.3.** Mangueras.

**2a.** Depósito 0,4 L.

**2b.** Depósito 1,5 L.

**4.** Adaptador para conexión de entrada de aire comprimido al módulo de AdBlue/DEF. (4a y 4b).

**5.** Adaptador para conexión de alimentación de aire comprimido desde el vehículo al módulo de AdBlue/DEF.

**6.** Botella de llenado.

**7.** Adaptador para entrada de AdBlue/DEF al módulo.

**8.** Adaptador para retorno de AdBlue/DEF al módulo.

**9.** Adaptadores de 3/8" para conexión en las tuberías de salida y retorno del depósito de AdBlue/DEF.

**10.** Adaptadores de 5/16" para conexión en las tuberías de salida y retorno del depósito de AdBlue/DEF.

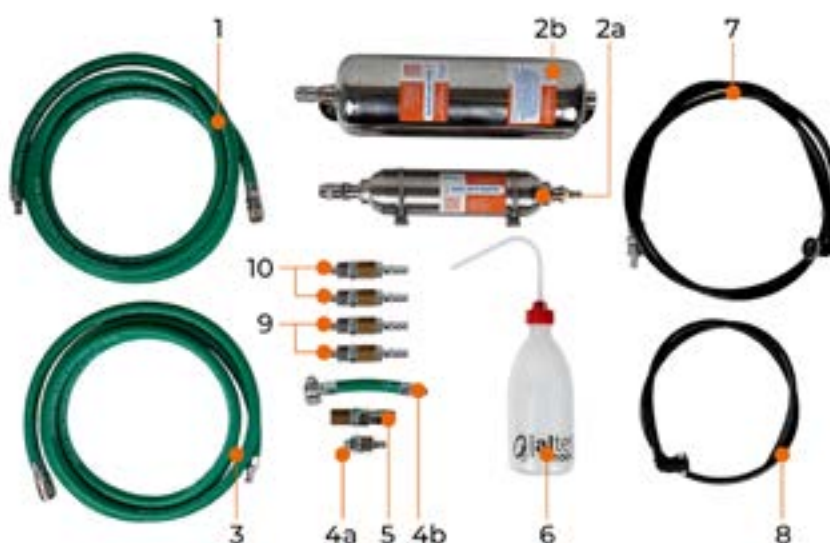

## 1.3 APLICACIÓN

- Sistema NoNOx (MAN TGL, TGM, TGS, TGX y autobuses Euro 6 con sistema AdBlue/DEF Emitec).
- Sistema AdBlue/DEF Emitec en vehículos con motor Cummins.
- Sistema AdBlue/DEF Albonair (VOLVO, RENAULT, UD Trucks y otros vehículos Euro 6).
- Sistema AdBlue/DEF Bosch Denoxtronic 2.2 y Denoxtronic 6-HD (DAF, IVECO, MAN, otros vehículos Euro 6, maquinaria agrícola, maquinaria de construcción, etc.).

## 1.4 PRECAUCIONES DE SEGURIDAD

Se deben tener en cuenta las siguientes precauciones de seguridad para evitar accidentes y/o lesiones:

- Colocar el vehículo en una superficie plana.
- Aplicar el freno de estacionamiento.
- Posicionar la palanca de cambio de marcha en punto muerto o neutro.
- Evitar el contacto con piezas que puedan permanecer a altas temperaturas o en movimiento.
- Utilizar una indumentaria adecuada.

## 2 Procedimiento

### 2.1 SISTEMA ADBLUE/DEF EMITEC (NONOX)

#### 2.1.1 PASOS PREVIOS

**a.** Realizar la prueba de vaciado del circuito de AdBlue/DEF con la herramienta de diagnóstico.

**Sistema NoNOx >> Chequeos del sistema >> “LLENADO Y PURGA DEL SISTEMA”**

**b.** Desmontar las chapas protectoras superior, delantera y lateral.



**c.** Desmontar los soportes de las chapas.



**d.** Desmontar la sujeción del inyector de AdBlue/DEF y extraer el inyector.

- Desmontar abrazadera.
- Desenroscar la tuerca del racor.
- Extraer el inyector de Adblue/DEF y volverlo a roscar en la tuerca del racor.
- Limpiar la tobera del inyector de AdBlue/DEF.



**Nota:** por comodidad durante las pruebas posteriores, desmontar las fijaciones del sensor NOx.

**e.** Desmontar las protecciones del módulo de AdBlue/DEF.



## 2.1.2 LIMPIEZA DEL CIRCUITO DE SALIDA DE ADBLUE/DEF

**a.** Evacuar la presión de alimentación neumática para mayor comodidad al desconectar o desmontar líneas por las que circula aire comprimido.

**b.** Desmontar la unión de entrada de aire comprimido al módulo de AdBlue/DEF (1).

**Nota:** si el vehículo dispone de aire a presión en el circuito, al desmontar la unión este aire comprimido se perderá.



1. Entrada de aire comprimido.
2. Conector eléctrico/Válvula de control del flujo de aire comprimido.
3. Conector eléctrico/Calefacción de la bomba AdBlue/DEF.
4. Entrada de AdBlue/DEF.
5. Salida/Mezcla de AdBlue/DEF y aire.
6. Retorno de AdBlue/DEF.

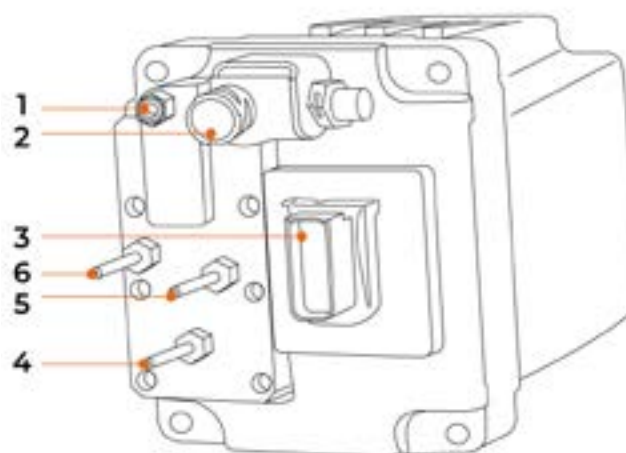

c. Conectar los adaptadores “4” (4a o 4b según convenga) y “5” en la entrada de aire comprimido del módulo de AdBlue/DEF (1) y en la salida de aire comprimido del vehículo. A continuación, acoplar una manguera (“1” y “3”) en cada adaptador pero sin conectarlas aún al depósito “2”.

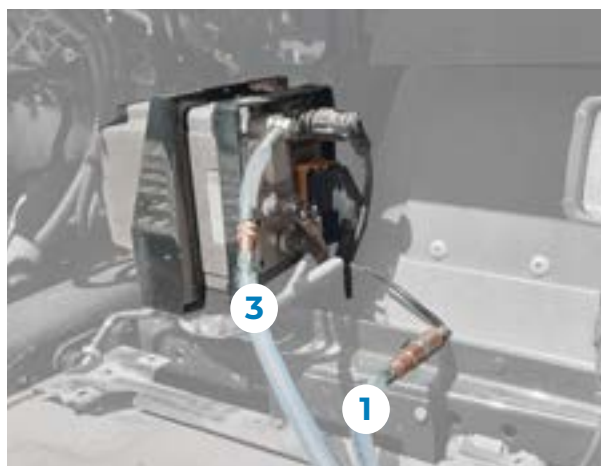

d. Llenar el depósito “2a” por la parte superior con 250 ml de agua destilada caliente (MÁX. 60 °C/140 °F), utilizando la botella de llenado “6”.





- e. Conectar las mangueras “1” y “3” al depósito “2a”.



- f. Arrancar el motor y mantenerlo hasta cargar el circuito de aire comprimido.
- g. Ejecutar con la herramienta de diagnóstico la acción correspondiente tantas veces como sea necesario hasta observar que por la boquilla del inyector solamente se expulsa aire comprimido. Utilizar un recipiente o probeta para recolectar los 250 ml de agua aproximadamente que se expulsarán por el inyector.

#### **Sistema NoNOx >> Chequeos del sistema >> “CHEQUEO DEL CIRCUITO DE AIRE”**

- h. Llevar a cabo de nuevo la instalación neumática previa a las pruebas. Montar la unión (1) de entrada de aire comprimido al módulo de AdBlue/DEF.

**Nota:** si no se despresuriza el circuito de aire comprimido, al desmontar las uniones este aire comprimido se perderá.

### 2.1.3 LIMPIEZA DEL CIRCUITO DE ENTRADA DE ADBLUE/DEF AL MÓDULO

- a. Arrancar el motor y mantenerlo hasta presurizar el circuito de aire comprimido.
- b. Desconectar las uniones (4) y (6) del módulo de AdBlue/DEF.
- c. Colocar un recipiente o tubo en la boca (6) para recoger la cantidad de líquido del retorno.
- d. Conectar la manguera “7” con enchufe rápido de 3/8” a la espiga de entrada de AdBlue/DEF (4). Conectar el otro extremo al enchufe rápido de la parte inferior del depósito “2a”.  
Previamente el depósito debe estar vacío y sin las mangueras de la prueba anterior.
- e. Rellenar el depósito “2a” con agua destilada caliente (MÁX. 60 °C/140 °F) por la parte superior. Tener en cuenta que la cantidad que se introduzca será aproximadamente la que se dosifique.



**f.** Ejecutar el chequeo de dosificación media. Utilizar un recipiente o probeta para recoger el agua que se dosificará por el inyector.

### **Sistema NoNOx >> Chequeos del sistema >> DOSIFICACIÓN DE ADBLUE/DEF>> “DOSIFICACIÓN MEDIA”**



## 2.1.4 PASOS POSTERIORES

- a.** Comprobar que no existen errores memorizados en la Unidad de Control.
- b.** Desmontar el equipo de limpieza del módulo de AdBlue/DEF y enjuagar con agua caliente todos los componentes incluido el depósito.
- c.** Montar las conexiones del módulo de AdBlue/DEF y comprobar la estanqueidad tanto del módulo como de las conexiones.
- d.** Montar protecciones de plástico del módulo de AdBlue/DEF.
- e.** Montar las chapas protectoras.



## 2.2 SISTEMA ADBLUE/DEF EMITEC (MOTOR CUMMINS)

### 2.2.1 PASOS PREVIOS

- a. Comprobar el sistema de dosificación de líquido AdBlue/DEF.
- b. Quitar contacto y desconectar las baterías.
- c. Liberar la presión del sistema de dosificación de AdBlue/DEF.
- d. Retirar el inyector de AdBlue/DEF.

**Nota:** colocar un recipiente adecuado en el extremo de la tubería.



### 2.2.2 LIMPIEZA DEL CIRCUITO DE SALIDA DE ADBLUE/DEF

- a. Desconectar la tubería de retorno de líquido AdBlue/DEF **(6)**.
- b. Desconectar la línea de alimentación de aire del módulo de dosificación de AdBlue/DEF **(1)**.

1. Entrada de aire comprimido.
2. Conector eléctrico/Válvula de control del flujo de aire comprimido.
3. Conector eléctrico/Calefacción de la bomba AdBlue/DEF.
4. Entrada de AdBlue/DEF.
5. Salida/Mezcla de AdBlue/DEF y aire.
6. Retorno de AdBlue/DEF.

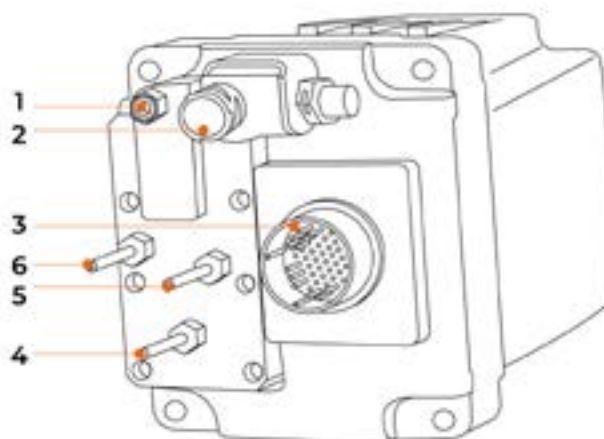



c. Conectar los adaptadores “4” (4a o 4b según convenga) y “5” en la entrada de aire comprimido del módulo de AdBlue/DEF (1) y en la salida de aire comprimido del vehículo. A continuación, acoplar una manguera (“1” y “3”) en cada adaptador, pero sin conectarlas aún al depósito “2a”.



d. Llenar el depósito “2a” por la parte superior con 250 ml de agua destilada caliente (MÁX. 60 °C/140 °F), utilizando la botella de llenado “6”.



e. Conectar las mangueras “1” y “3” al depósito “2a”.

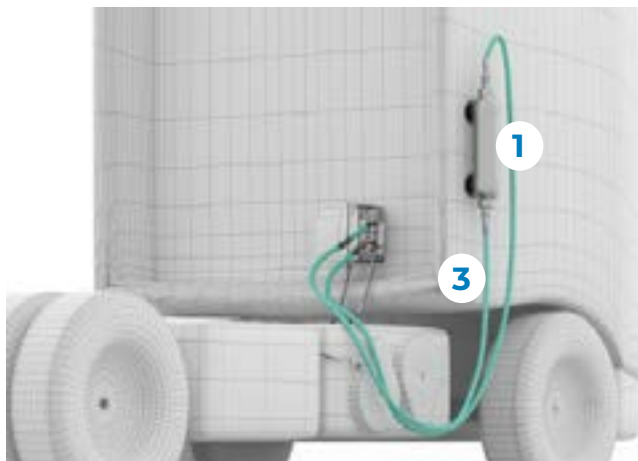



f. Arrancar el motor.

g. Ejecutar con la herramienta de diagnóstico la acción correspondiente tantas veces como sea necesario hasta observar que por la boquilla del inyector solamente se expulsa aire comprimido. Utilizar un recipiente o probeta para recolectar los 250 ml de agua aproximadamente que se expulsarán por el inyector.

### Actuar componentes >> “ELECTROVÁLVULA DE LA BOMBA DE DOSIFICACIÓN ADBLUE/DEF”

**Nota:** en este caso, la acción indicada sirve únicamente para garantizar la correcta limpieza del circuito de AdBlue/DEF.

h. Volver a conectar todos los elementos desconectados.

## 2.2.3 LIMPIEZA DEL CIRCUITO DE ENTRADA DE ADBLUE/DEF AL MÓDULO

a. Desconectar la tubería de alimentación de AdBlue/DEF del módulo de dosificación (4).

b. Desconectar la tubería de retorno de líquido AdBlue/DEF (6).

c. Colocar un recipiente o tubo en la boca (6) para recoger la cantidad de líquido del retorno.

d. Conectar la manguera “7” con enchufe rápido de 3/8” a la espiga de entrada de AdBlue/DEF (4).



e. Conectar la manguera al depósito “2a”.

Previamente el depósito debe estar vacío y sin las mangueras de la prueba anterior.





**f.** Llenar el depósito “2a” con 250 ml de agua destilada caliente (MÁX. 60 °C/140 °F) por la parte superior.

**g.** Arrancar el motor.

**h.** Ejecutar con la herramienta de diagnóstico la acción correspondiente y evaluar el resultado. Utilizar un recipiente o probeta para recolectar el agua que se dosificará por el inyector. Si el agua no se drena por completo, repetir la acción.

### **Cheques del sistema >> “BOMBA ADBLUE/DEF”**

**Nota:** en este caso, la acción indicada sirve únicamente para garantizar la correcta limpieza del circuito de AdBlue/DEF.

**i.** Volver a conectar todos los elementos desconectados.

## 2.2.4 PASOS POSTERIORES

**a.** Comprobar que no existen errores memorizados en la Unidad de Control.

**b.** Desmontar el equipo de limpieza del módulo de AdBlue/DEF y enjuagar con agua caliente todos los componentes, incluido el depósito.

**c.** Montar las conexiones del módulo de AdBlue/DEF y comprobar la estanqueidad tanto del módulo como de las conexiones.

## 2.3 SISTEMA ADBLUE/DEF ALBONAIR

### 2.3.1 PASOS PREVIOS

**a.** Realizar la prueba de purga del circuito de AdBlue/DEF con la herramienta de diagnóstico.

### **Sistema ACM >> Cheques del sistema >> “PURGA DEL CIRCUITO DE ADBLUE/DEF”**

**b.** Desmontar las chapas protectoras.



Para mayor comodidad durante el proceso, desmontar igualmente el soporte de la chapa lateral.



**c.** Desmontar la sujeción del inyector de AdBlue/DEF y extraer el inyector.



**d.** Colocar un recipiente en la boquilla del inyector.



## 2.3.2 LIMPIEZA DEL CIRCUITO DE ADBLUE/DEF

a. Desconectar la unión de entrada de AdBlue/DEF al módulo (3).

**Nota:** limpiar restos de AdBlue/DEF que puedan caer tras la desconexión.

- A.** Bomba AdBlue/DEF.
- B.** Válvula de calefacción del depósito de AdBlue/DEF.
- C.** Sensor de temperatura de AdBlue/DEF / Válvula de control de aire.
- D.** Sensor de presión de aire.
- E.** Sensor de presión de AdBlue/DEF.

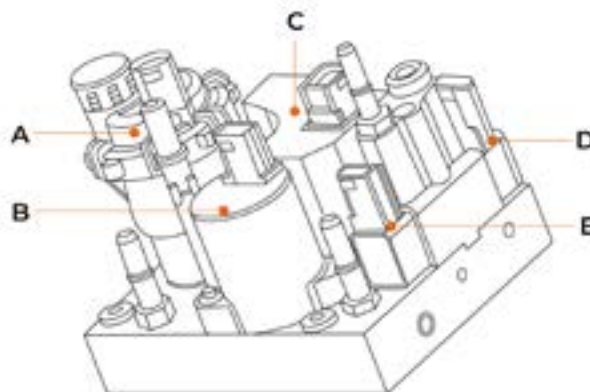

- 1.** Entrada de líquido refrigerante.
- 2.** Entrada de aire comprimido.
- 3.** Entrada de AdBlue/DEF.

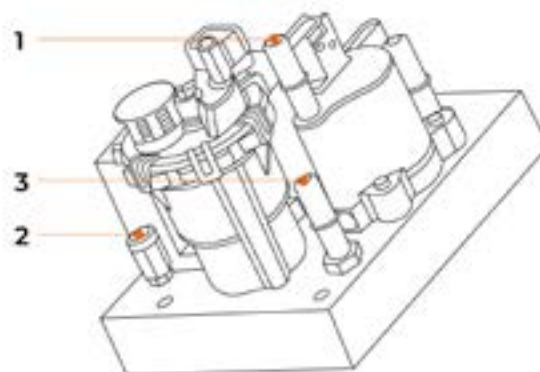

- 4.** Salida de líquido refrigerante.
- 5.** Salida de aire.
- 6.** Salida de AdBlue/DEF.

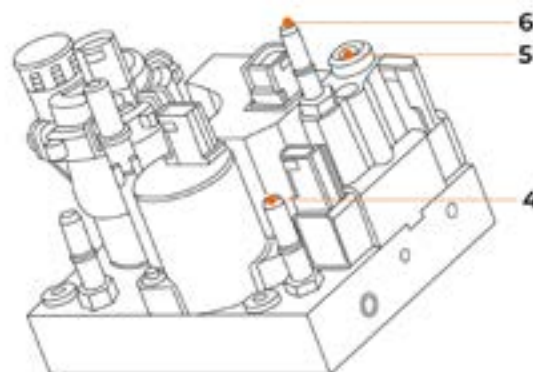



**b.** Conectar la manguera “7” con enchufe rápido 3/8” a la espiga de entrada de AdBlue/DEF (3).



**c.** Conectar el otro extremo de la manguera “7” al enchufe rápido de la parte inferior del depósito “2a”.

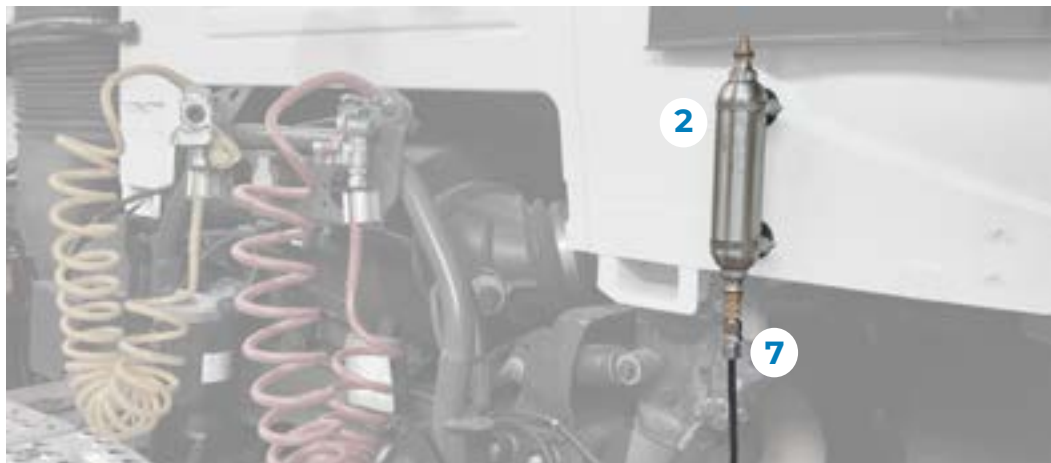

**d.** Llenar el depósito “2a” por la parte superior con 200 ml aproximadamente de agua destilada caliente (MÁX. 60 °C/140 °F), utilizando la botella de llenado “6”.







e. Ejecutar con la herramienta de diagnóstico el chequeo de limpieza del módulo de AdBlue/DEF.

### **Sistema ACM >> Chequeos del sistema >> “LIMPIEZA DEL MÓDULO DE ADBLUE/DEF”**

**Nota:** para considerar que el circuito de AdBlue/DEF no está obstruido y que el sistema funciona correctamente, el volumen de agua dosificado debe estar entre los valores máximo y mínimo mostrados al finalizar la acción.

## 2.3.3 PASOS POSTERIORES

- a. Comprobar que no existen errores memorizados en la Unidad de Control.
- b. Desconectar la herramienta de diagnóstico y quitar contacto del vehículo.
- c. Desmontar el equipo de limpieza del módulo de AdBlue/DEF y enjuagar con agua caliente todos los componentes incluido el depósito.
- d. Montar la conexión del módulo de AdBlue/DEF y comprobar la estanqueidad tanto del módulo como de las conexiones.
- e. Montar el inyector de AdBlue/DEF.
- f. Montar las chapas protectoras.

## 2.4 SISTEMA ADBLUE/DEF BOSCH DENOXTRONIC 2.2 Y DENOXTRONIC 6-HD

### 2.4.1 PASOS PREVIOS

- a. Realizar la purga del circuito de AdBlue/DEF.

**Nota:** quitar el contacto y esperar 2 minutos antes de volver a dar contacto.



**b.** Localizar el módulo de dosificación de AdBlue/DEF.

**Nota:** la ubicación depende del vehículo.

**c.** Desmontar las chapas protectoras en el caso que sea necesario.

**d.** Desmontar la sujeción del inyector de AdBlue/DEF y extraer el inyector.

**Nota:** la ubicación depende del vehículo.



**e.** Colocar un recipiente en la boquilla del inyector.

## 2.4.2 LIMPIEZA DEL CIRCUITO DE ADBLUE/DEF

**a.** Desconectar la tubería de alimentación de AdBlue/DEF del módulo de dosificación **(6)**.

**Nota:** limpiar los restos de AdBlue/DEF que puedan caer durante la desconexión.

**b.** Desconectar la tubería de retorno de líquido AdBlue/DEF hacia el depósito **(4)**.

- 1.** Salida de AdBlue/DEF.
- 2.** Salida de líquido refrigerante.
- 3.** Entrada de líquido refrigerante.
- 4.** Retorno de AdBlue/DEF.
- 5.** Conector eléctrico.
- 6.** Entrada de AdBlue/DEF.

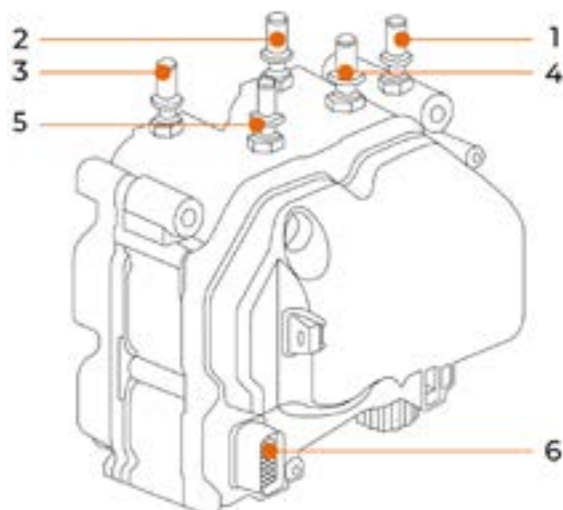

c. Conectar la manguera “7” con enchufe rápido de 3/8” a la espiga de entrada de AdBlue/DEF (6).

d. Conectar el adaptador “8” a la espiga de retorno de AdBlue/DEF (4) y colocar un recipiente en el extremo libre.

**Nota:** durante la prueba, y dependiendo del vehículo, el volumen de agua de retorno puede llegar a 700 ml aproximadamente.



e. Conectar el otro extremo de la manguera “7” al enchufe rápido de la parte inferior del depósito “2b”.

**Nota:** fijar el depósito a una altura superior a la de la toma de entrada de AdBlue/DEF del módulo de dosificación.



f. Llenar el depósito “2b” por la parte superior con agua destilada caliente (MÁX. 60 °C/140 °F), utilizando la botella de llenado “6”.



**g.** Ejecutar con la herramienta de diagnóstico la acción de limpieza del módulo de AdBlue/DEF.

### **Mantenimiento >> “LIMPIEZA DEL MÓDULO DE ADBLUE/DEF”**

**Nota:** para considerar que el circuito de AdBlue/DEF no está obstruido y que el sistema funciona correctamente, el volumen de agua dosificado debe estar entre los valores máximo y mínimo mostrados al finalizar la acción.

## 2.4.3 PASOS POSTERIORES

- a.** Comprobar que no existen errores memorizados en la unidad de control.
- b.** Desconectar la manguera “7” de la parte inferior del depósito “2b”.
- c.** Desconectar la herramienta de diagnóstico y quitar contacto del vehículo.

**Importante:** el sistema debe expulsar de forma automática el agua restante de las tuberías antes de continuar con el siguiente paso.

- d.** Desmontar el equipo de limpieza del módulo de AdBlue/DEF y enjuagar con agua caliente todos los componentes incluido el depósito.
- e.** Montar todos los componentes desmontados en pasos previos.

# ●.cojali

Jaltest.com  
cojali.com

2023 V.1 ES



Local Distributor



**Kit pour le nettoyage du  
module d'AdBlue/DEF**

Manuel de l'utilisateur

[jaltest.com](http://jaltest.com)



Rev. 01



## Kit pour le nettoyage du module d'AdBlue/DEF

Manuel de l'utilisateur

**cojali**

INNOVATION & TECHNOLOGY



# Sommaire

Sommaire	3
Information générale	4
1.1 DESCRIPTION DU PRODUIT	4
1.2 CONTENU	4
1.3 APPLICATION	4
1.4 PRÉCAUTIONS DE SÉCURITÉ	5
Processus	6
2.1 SYSTÈME ADBLUE/DEF EMITEC (NONOX)	6
2.1.1 ÉTAPES PRÉCÉDENTES	6
2.1.2 NETTOYAGE DU CIRCUIT DE SORTIE D'ADBLUE/DEF	7
2.1.3 NETTOYAGE DU CIRCUIT D'ENTRÉE D'ADBLUE/DEF AU MODULE	9
2.1.4 ÉTAPES SUIVANTES	10
2.2 SYSTÈME ADBLUE/DEF EMITEC (MOTEUR CUMMINS)	11
2.2.1 ÉTAPES PRÉCÉDENTES	11
2.2.2 NETTOYAGE DU CIRCUIT DE SORTIE D'ADBLUE/DEF	11
2.2.3 NETTOYAGE DU CIRCUIT D'ENTRÉE D'ADBLUE/DEF AU MODULE	13
2.2.4 ÉTAPES SUIVANTES	14
2.3 SYSTÈME ADBLUE/DEF ALBONAIR	14
2.3.1 ÉTAPES PRÉCÉDENTES	14
2.3.2 NETTOYAGE DU CIRCUIT D'ADBLUE/DEF	16
2.3.3 ÉTAPES SUIVANTES	18
2.4 SYSTÈME ADBLUE/DEF BOSCH DENOXTRONIC 2.2 ET DENOXTRONIC 6-HD	18
2.4.1 ÉTAPES PRÉCÉDENTES	18
2.4.2 NETTOYAGE DU CIRCUIT D'ADBLUE/DEF	19
2.4.3 ÉTAPES SUIVANTES	21

## Navigation facile

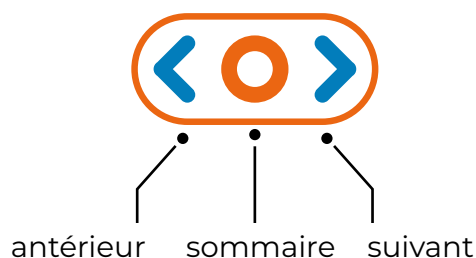

Accédez plus rapidement au contenu dont vous avez besoin en cliquant



# 1 Information générale

## 1.1 DESCRIPTION DU PRODUIT

Équipement pour réaliser le nettoyage des restes d'AdBlue/DEF cristallisé dans le module de dosage, le conduit de l'injecteur et le propre injecteur.

## 1.2 CONTENU

**1. 2.** Tuyaux.

**2.** Réservoir 0,4 L.

**3.** Réservoir 1,5 L.

**4.** Adaptateur pour la connexion d'entrée d'air comprimé au module d'AdBlue/DEF. (4a et 4b).

**5.** Adaptateur pour la connexion d'alimentation d'air comprimé du véhicule au module d'AdBlue/DEF.

**6.** Bouteille de remplissage.

**7.** Adaptateur pour entrée d'AdBlue/DEF au module.

**8.** Adaptateur pour retour d'AdBlue/DEF au module.

**9.** Adaptateurs de 3/8" pour la connexion sur les tuyaux de sortie et de retour du réservoir d'AdBlue/DEF.

**10.** Adaptateurs de 5/16" pour la connexion sur les tuyaux de sortie et de retour du réservoir d'AdBlue/DEF.

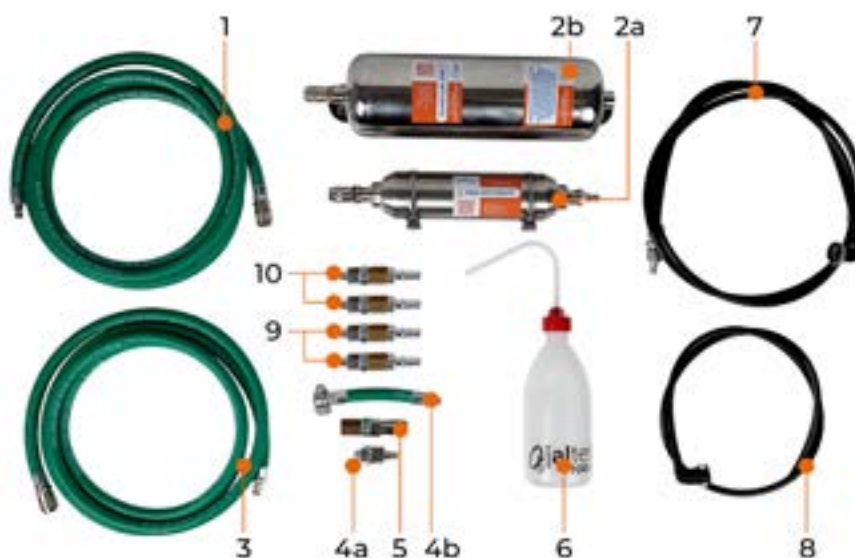

## 1.3 APPLICATION

- Système NoNOX (MAN TGL, TGM, TGS, TGX et autobus Euro 6 avec système AdBlue Emitec).
- Système AdBlue/DEF Emitec sur les véhicules avec moteur Cummins.
- Système AdBlue/DEF Albonair (VOLVO, RENAULT, UD Trucks et d'autres véhicules Euro 6).
- Système AdBlue/DEF Bosch Denoxtronic 2.2 et Denoxtronic 6-HD (DAF, IVECO, MAN, d'autres véhicules Euro 6, machines agricoles, machines de construction, etc.).

## 1.4 PRÉCAUTIONS DE SÉCURITÉ

Il faut prendre en considération les précautions suivantes de sécurité pour éviter des accidents et/ou des blessures

- Placer le véhicule sur une surface plane.
- Serrer le frein de stationnement.
- Placer le levier de changement de vitesse au point mort ou neutre.
- Éviter le contact avec des pièces qui peuvent être à des températures élevées ou en mouvement.
- Porter une tenue appropriée.

## 2 Processus

### 2.1 SYSTÈME ADBLUE/DEF EMITEC (NONOX)

#### 2.1.1 ÉTAPES PRÉCÉDENTES

- a. Réaliser le test de vidange du circuit d'AdBlue/DEF avec l'outil de diagnostic.

#### **Systeme NoNOx >> Vérifications du système "REPLISSAGE ET PURGE DU SYSTÈME"**

- b. Démonter les plaques de protection supérieure, avant et latérale.



- c. Démonter les supports des plaques.





**d.** Démonter la fixation de l'injecteur d'AdBlue/DEF et extraire l'injecteur.

- Démonter le collier de serrage.
- Dévisser l'écrou du raccord.
- Extraire l'injecteur d'Adblue/DEF et le visser à nouveau dans l'écrou du raccord.
- Nettoyer la soupape de l'injecteur d'AdBlue/DEF.



**Remarque:** pour plus de commodité lors des tests postérieurs, démonter les fixations du capteur NOx.

**e.** Démonter les protections du module d'AdBlue/DEF.



## 2.1.2 NETTOYAGE DU CIRCUIT DE SORTIE D'ADBLUE/DEF

- a.** Évacuer la pression d'alimentation pneumatique pour plus de commodité au moment de déconnecter et démonter les lignes par lesquelles circule l'air comprimé.
- b.** Démonter l'union d'entrée d'air comprimé au module d'AdBlue/DEF **(1)**.

**Remarque:** si le véhicule dispose d'air à pression dans le circuit, en démontant l'union cet air comprimé se perdra.



1. Entrée d'air comprimé.
2. Connecteur électrique/Valve de contrôle du flux d'air comprimé.
3. Connecteur électrique/Chauffage de la pompe AdBlue/DEF.
4. Entrée d'AdBlue/DEF.
5. Sortie/Mélange d'AdBlue/DEF et air.
6. Retour d'AdBlue/DEF.

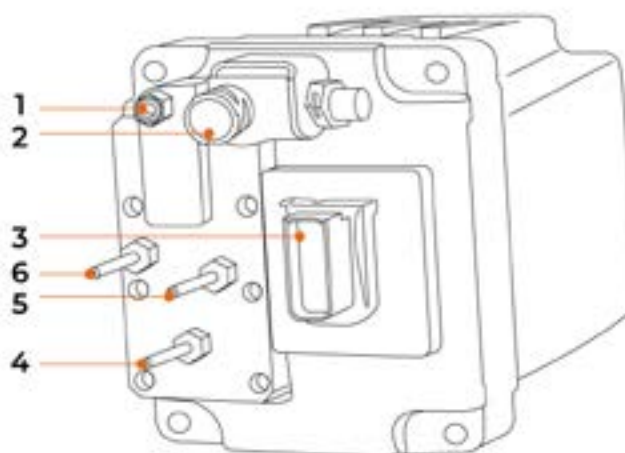

**c.** Connecter les adaptateurs "4" (4a ou 4b selon les besoins) et "5" dans l'entrée d'air comprimé du module d'AdBlue/DEF (1) et dans la sortie d'air comprimé du véhicule. Ensuite, accoupler un tuyau ("1" et "3") à chaque adaptateur mais sans les connecter encore au "2".

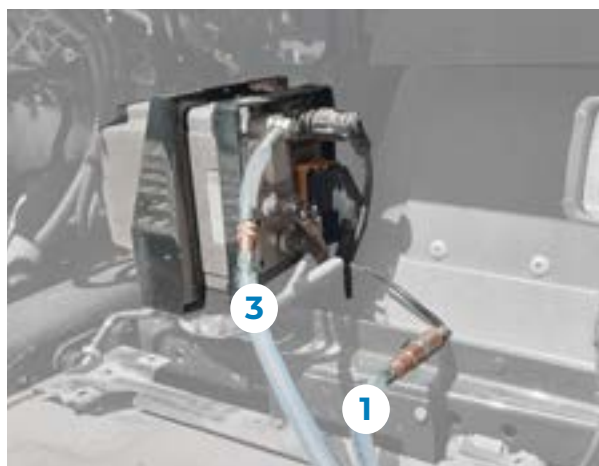

**d.** Remplir le réservoir "2a" par la partie supérieure avec 250 ml d'eau distillée chaude (MAX. 60 °C/140 °F), en utilisant la bouteille de remplissage "6".





e. Connecter les tuyaux “1” et “3” au réservoir “2a”.



f. Démarrer le moteur et le maintenir jusqu'à charger le circuit d'air comprimé.

g. Exécuter avec l'outil de diagnostic l'action correspondante autant de fois comme nécessaire jusqu'à observer que par la buse de l'injecteur seulement est expulsé de l'air comprimé. Utiliser un récipient ou une éprouvette pour prélever les 250 ml d'eau environ qui seront expulsés par l'injecteur.

### **Système NoNOx >> Vérifications du système “VÉRIFICATION DU CIRCUIT D'AIR”**

h. Effectuer à nouveau l'installation pneumatique préalable aux tests. Monter l'union (1) d'entrée d'air comprimé au module d'AdBlue/DEF

**Remarque:** si le circuit d'air comprimé n'est pas dépressurisé, en démontant les unions cet air comprimé se perdra.

## 2.1.3 NETTOYAGE DU CIRCUIT D'ENTRÉE D'ADBLUE/DEF AU MODULE

a. Démarrer le moteur et le maintenir jusqu'à pressuriser le circuit d'air comprimé.

b. Déconnecter les unions (4) et (6) du module d'AdBlue/DEF.

c. Placer un récipient ou un tuyau dans la bouche (6) pour récupérer la quantité de liquide de retour.

d. Raccordez le tuyau “7” avec un raccord rapide 3/8” à l'embout d'entrée d'AdBlue/DEF (4). Connecter l'autre extrémité au connecteur rapide de la partie inférieure du réservoir “2a”.

Auparavant, le réservoir doit être vide et sans les tuyaux du test précédent.

e. Remplir le réservoir “2a” avec de l'eau distillée chaude (MÁX. 60 °C/140 °F) par la partie supérieure. Prendre en considération que la quantité introduite est environ celle qui est dosée.

**f.** Exécuter la vérification de dosage moyen. Utiliser un récipient ou une éprouvette pour récupérer l'eau qui sera dosée par l'injecteur.

**Systeme NoNOx >> Vérifications du système >> DOSAGE D'ADBLUE/DEF >> "DOSAGE MOYEN"**



## 2.1.4 ÉTAPES SUIVANTES

- a.** Vérifier qu'il n'existe pas d'erreurs dans la mémoire de l'Unité de Contrôle.
- b.** Démonter l'équipement de nettoyage du module d'AdBlue/DEF et rincer avec de l'eau chaude tous les composants y compris le réservoir.
- c.** Monter les connexions du module d'AdBlue/DEF et vérifier l'étanchéité du module comme des connexions.
- d.** Monter les protections en plastique du module d'AdBlue/DEF.
- e.** Monter les plaques de protection.

## 2.2 SYSTÈME ADBLUE/DEF EMITEC (MOTEUR CUMMINS)

### 2.2.1 ÉTAPES PRÉCÉDENTES

- a. Vérifier le système de dosage du liquide AdBlue/DEF
- b. Enlever le contact et déconnecter les batteries
- c. Libérer la pression du système de dosage d'AdBlue/DEF
- d. Retirer l'injecteur d'AdBlue/DEF

**Note:** placer un récipient adéquat à l'extrémité du tuyau



### 2.2.2 NETTOYAGE DU CIRCUIT DE SORTIE D'ADBLUE/DEF

- a. Démontez le tuyau de retour du liquide AdBlue/DEF (6)
- b. Déconnectez la ligne d'alimentation d'air du module de dosage d'AdBlue/DEF (1)

1. Entrée d'air comprimé.
2. Connecteur électrique/Valve de contrôle du flux d'air comprimé.
3. Connecteur électrique/Chauffage de la pompe AdBlue/DEF.
4. Entrée d'AdBlue/DEF.
5. Sortie/Mélange d'AdBlue/DEF et air.
6. Retour d'AdBlue/DEF.

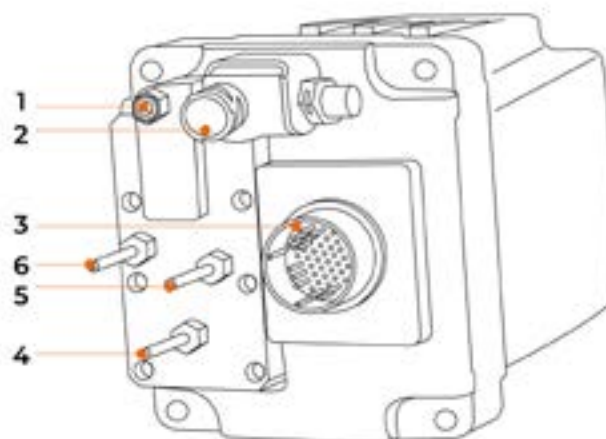





**c.** Connecter les adaptateurs “4” (4a ou 4b selon les besoins) et “5” à l’entrée d’air comprimé du module d’AdBlue/DEF (1) et à la sortie d’air comprimé du véhicule. Ensuite, raccorder un tuyau (“1” et “3”) à chaque adaptateur, mais sans les connecter encore au réservoir “2a”.



**d.** Remplir le réservoir “2a” par la partie supérieure avec 250 ml d’eau distillée chaude (MAX. 60 °C/140 °F), en utilisant la bouteille de remplissage “6”.



**e.** Connecter les tuyaux “1” et “3” au réservoir “2a”

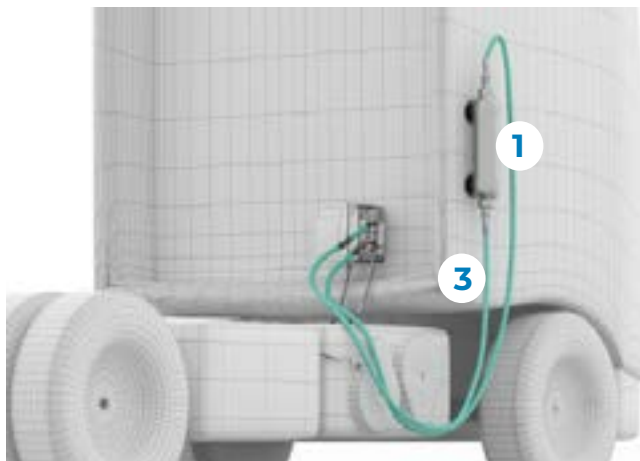



- f. Démarrer le moteur
- g. Exécuter avec l'outil de diagnostic l'action correspondante autant de fois comme nécessaire jusqu'à observer que par la buse de l'injecteur seulement est expulsé de l'air comprimé. Utiliser un récipient ou une éprouvette pour prélever les 250 ml d'eau environ qui seront expulsés par l'injecteur.

### Actionner composants >> "ÉLECTROVALVE DE LA POMPE DE DOSAGE ADBLUE/DEF"

**Note:** dans ce cas-là, l'action indiquée sert uniquement à garantir le bon nettoyage du circuit d'AdBlue/DEF.

- h. Connecter à nouveau tous le éléments déconnectés.

## 2.2.3 NETTOYAGE DU CIRCUIT D'ENTRÉE D'ADBLUE/DEF AU MODULE

- a. Déconnecter le tuyau d'alimentation d'AdBlue/DEF du module de dosage (4).
- b. Déconnecter le tuyau de retour du liquide AdBlue/DEF (6).
- c. Placer un récipient ou un tuyau dans la bouche (6) pour récupérer la quantité de liquide de retour.
- d. Connecter le tuyau "7" avec prise rapide de 3/8" à la tige d'entrée d'AdBlue/DEF (4).



- e. Connecter le tuyau au réservoir "2a".

Auparavant, le réservoir doit être vide et sans les tuyaux du test précédent.





**f.** Remplir le réservoir “2a” avec 250 ml d’eau distillée chaude (MAX. 60 °C/140 °F), par la partie supérieure.

**g.** Démarrer le moteur

**h.** Exécuter avec l’outil de diagnostic l’action correspondante et évaluer le résultat. Utiliser un récipient ou une éprouvette pour prélever l’eau qui sera dosée par l’injecteur. Si l’eau ne se draine pas complètement, répéter l’action.

### **Vérifications du système >> “POMPE ADBLUE/DEF”**

**Note:** dans ce cas-là, l’action indiquée sert uniquement à garantir le bon nettoyage du circuit d’AdBlue/DEF.

**i.** Connecter à nouveau tous le éléments déconnectés.

## 2.2.4 ÉTAPES SUIVANTES

**a.** Vérifier qu’il n’existe pas d’erreurs gardées dans la mémoire de l’Unité de Contrôle.

**b.** Démontez l’équipement de nettoyage du module d’AdBlue/DEF et rincer avec de l’eau chaude tous les composants y compris le réservoir.

**c.** Monter les connexions du module d’AdBlue/DEF et vérifier l’étanchéité du module comme des connexions.

## 2.3 SYSTÈME ADBLUE/DEF ALBONAIR

### 2.3.1 ÉTAPES PRÉCÉDENTES

**a.** Réaliser le test de purge du circuit d’AdBlue/DEF avec l’outil de diagnostic.

### **Système ACM >> Contrôles du système >> “PURGE DU CIRCUIT D’ADBLUE/DEF”**

**b.** Démontez les plaques de protection.



Pour plus de commodité pendant le processus, démonter également le support de la plaque latérale.



**c.** Démonter la fixation de l'injecteur d'AdBlue/DEF et extraire l'injecteur.



**d.** Placer un récipient à la buse de l'injecteur.





## 2.3.2 NETTOYAGE DU CIRCUIT D'ADBLUE/DEF

a. Déconnecter l'union d'entrée d'AdBlue/DEF au module **(3)**.

**Note:** nettoyer les restes d'AdBlue/DEF qui peuvent tomber après la déconnexion.

- A.** Pompe AdBlue/DEF.
- B.** Valve de chauffage du réservoir d'AdBlue/DEF.
- C.** Capteur de température d'AdBlue/DEF / Valve de contrôle d'air.
- D.** Capteur de pression d'air.
- E.** Capteur de pression d'AdBlue/DEF.

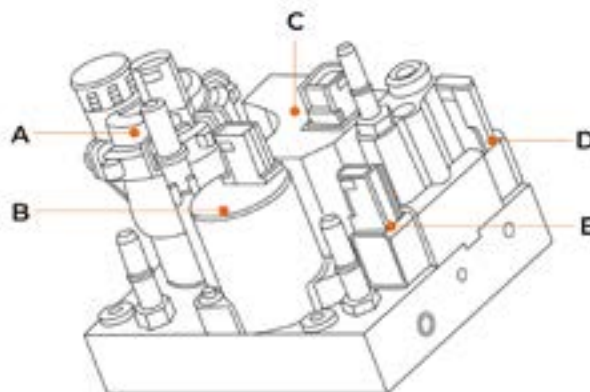

- 1.** Entrée du liquide de refroidissement.
- 2.** Entrée d'air comprimé.
- 3.** Entrée d'AdBlue/DEF.

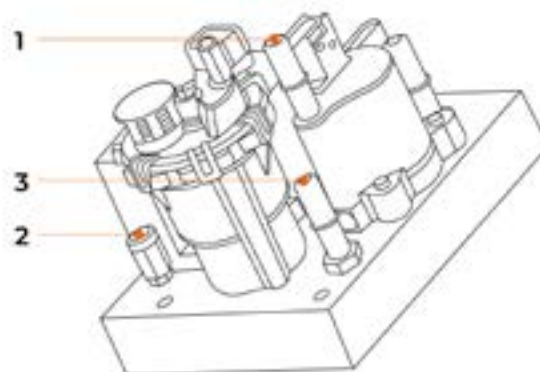

- 4.** Sortie du liquide de refroidissement.
- 5.** Sortie d'air.
- 6.** Sortie d'AdBlue/DEF.

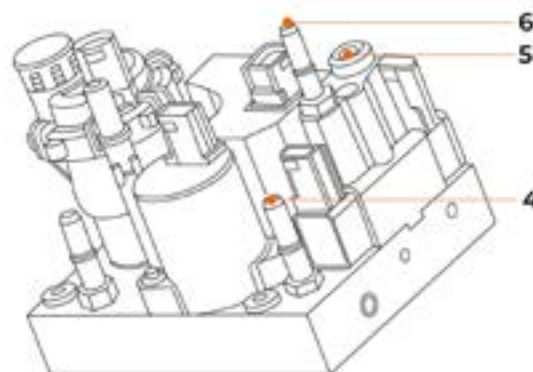



**b.** Connecter le tuyau “7” avec raccord rapide de 3/8” à la tige d’entrée d’AdBlue/DEF (3).



**c.** Connecter l’autre extrémité au tuyau “7” au raccord rapide de la partie inférieure du réservoir “2a”.

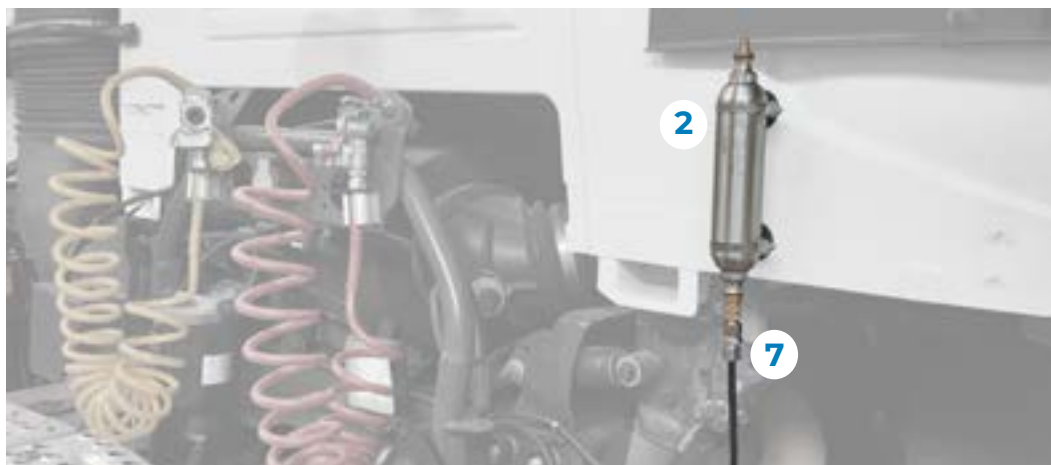

**d.** Remplir le réservoir “2a” par la partie supérieure avec environ 200 ml d’eau distillée chaude (MAX. 60 °C/140 °F), en utilisant la bouteille de remplissage “6”.





e. Exécuter avec l'outil de diagnostic la vérification du nettoyage du module d'AdBlue/DEF.

### **Système ACM >> Contrôles du système >> "NETTOYAGE DU MODULE D'ADBLUE/DEF"**

**Note :** pour considérer que le circuit d'AdBlue/DEF n'est pas obstrué et que le système fonctionne correctement, le volume d'eau dosé doit être entre les valeurs maximale et minimale montrées en terminant l'action.

## 2.3.3 ÉTAPES SUIVANTES

- a. Vérifier qu'il n'existe pas d'erreurs gardées dans la mémoire de l'Unité de Contrôle.
- b. Déconnecter l'outil de diagnostic et enlever le contact du véhicule.
- c. Démonter l'équipement de nettoyage du module d'AdBlue/DEF et rincer avec de l'eau chaude tous les composants y compris le réservoir.
- d. Monter la connexion du module d'AdBlue/DEF et vérifier l'étanchéité du module comme des connexions.
- e. Monter l'injecteur d'AdBlue/DEF.
- f. Monter les plaques de protection.

## 2.4 SYSTÈME ADBLUE/DEF BOSCH DENOXTRONIC 2.2 ET DENOXTRONIC 6-HD

### 2.4.1 ÉTAPES PRÉCÉDENTES

- a. Réaliser la purge du circuit d'AdBlue/DEF.

**Note:** enlever le contact et attendre 2 minutes avant de remettre le contact.



**b.** Localiser le module de dosage d'AdBlue/DEF.

**Note:** l'emplacement dépend du véhicule.

**c.** Démonter les plaques de protection si nécessaire.

**d.** Démonter la fixation de l'injecteur d'AdBlue/DEF et extraire l'injecteur.

**Note:** l'emplacement dépend du véhicule.



**e.** Placer un récipient à la buse de l'injecteur.

## 2.4.2 NETTOYAGE DU CIRCUIT D'ADBLUE/DEF

**a.** Déconnecter le tuyau d'alimentation d'AdBlue/DEF du module de dosage **(6)**.

**Note:** nettoyer les restes d'AdBlue/DEF qui peuvent tomber durant la déconnexion.

**b.** Déconnecter le tuyau de retour du liquide AdBlue/DEF vers le réservoir **(4)**.

- 1.** Sortie d'AdBlue/DEF.
- 2.** Sortie du liquide de refroidissement.
- 3.** Entrée du liquide de refroidissement.
- 4.** Retour d'AdBlue/DEF.
- 5.** Connecteur électrique.
- 6.** Entrée d'AdBlue/DEF.

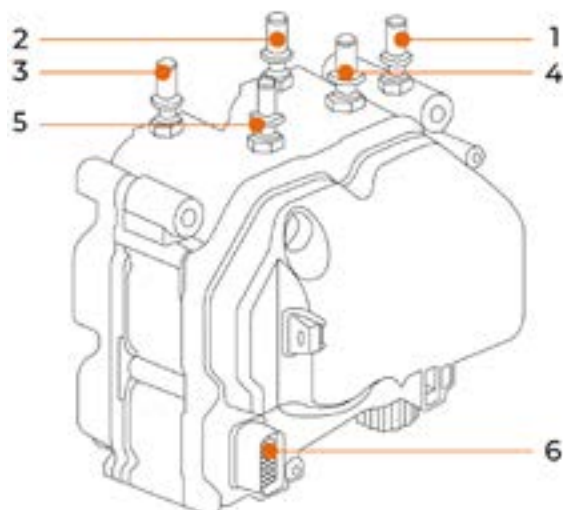



c. Connecter le tuyau “7” avec raccord rapide de 3/8” à la tige d’entrée d’AdBlue/DEF (6).

d. Connecter l’adaptateur “8” à la tige de retour d’AdBlue/DEF (4) et placer un récipient sur l’extrémité libre.

**Note:** durant le test, et en fonction du véhicule, le volume d’eau de retour peut arriver à environ 700 ml.



e. Connecter l’autre extrémité du tuyau “7” au raccord rapide de la partie inférieure du réservoir “2b”.

**Note:** fixer le réservoir à une hauteur supérieure à celle de la prise d’entrée d’AdBlue/DEF du module de dosage.



f. Remplir le réservoir “2b” par la partie supérieure avec de l’eau distillée chaude (MAX. 60 °C/140 °F), en utilisant la bouteille de remplissage “6”.



- g.** Exécuter avec l'outil de diagnostic l'action de nettoyage du module d'AdBlue/DEF.

## Maintenance >> "NETTOYAGE DU MODULE D'ADBLUE/DEF"

**Note:** pour considérer que le circuit d'AdBlue/DEF n'est pas obstrué et que le système fonctionne correctement, le volume d'eau dosé doit être entre les valeurs maximale et minimale montrées en terminant l'action.

### 2.4.3 ÉTAPES SUIVANTES

- a.** Vérifier qu'il n'y a pas d'erreurs mémorisées dans l'unité de contrôle.
- b.** Déconnecter le tuyau "7" de la partie inférieure du réservoir "2b".
- c.** Déconnecter l'outil de diagnostic et enlever le contact du véhicule.

**Important:** le système doit expulser automatiquement l'eau restante des tuyaux avant de continuer avec l'étape suivante.

- d.** Démonter l'équipement de nettoyage du module d'AdBlue/DEF et rincer avec de l'eau chaude tous les composants y compris le réservoir.
- e.** Monter tous les composants démontés dans les étapes précédentes.

# ●.cojali

Jaltest.com  
cojali.com

2023 V.1 FR



Local Distributor



**Kit zur Reinigung des  
AdBlue/DEF-Moduls**

Benutzerhandbuch

[jaltest.com](http://jaltest.com)

**cojali**  
INNOVATION & TECHNOLOGY



Rev. 01



## Kit zur Reinigung des AdBlue/DEF-Moduls

Benutzerhandbuch

**cojali**

INNOVATION & TECHNOLOGY



# Inhaltsverzeichnis

Inhaltsverzeichnis	3
Allgemeine Informationen	4
1.1 PRODUKTBESCHREIBUNG	4
1.2 INHALT	4
1.3 ANWENDUNG	4
1.4 SICHERHEITSVORKEHRUNGEN	5
Verfahren	6
2.1 ADBLUE/DEF EMITEC SYSTEM (NONOX)	6
2.1.1 SCHRITTE VORHER	6
2.1.2 REINIGUNG DES ADBLUE/DEF- AUSLASSKREISLAUFES	7
2.1.3 REINIGUNG DES ADBLUE/DEF- EINLASSKREISLAUFES BEIM MODUL	9
2.1.4 SCHRITTE NACHHER	9
2.2 ADBLUE/DEF EMITEC SYSTEM (CUMMINS MOTOR)	10
2.2.1 SCHRITTE VORHER	11
2.2.2 REINIGUNG DES ADBLUE/DEF-AUSLASSKREISLAUFES	11
2.2.3 REINIGUNG DES ADBLUE/DEF-EINLASSKREISLAUFES BEIM MODUL	13
2.2.4 SCHRITTE NACHHER	13
2.3 ALBONAIR ADBLUE/DEF-SYSTEM	14
2.3.1 SCHRITTE VORHER	14
2.3.2 REINIGUNG DES ADBLUE/DEF-KREISLAUFES	16
2.3.3 SCHRITTE NACHHER	18
2.4 BOSCH-ADBLUE/DEF-SYSTEM DENOXTRONIC 2.2 UND DENOXTRONIC 6-HD	18
2.4.1 SCHRITTE VORHER	18
2.4.2 REINIGUNG DES ADBLUE/DEF-KREISLAUFES	19
2.4.3 SCHRITTE NACHHER	21

## Einfaches Surfen

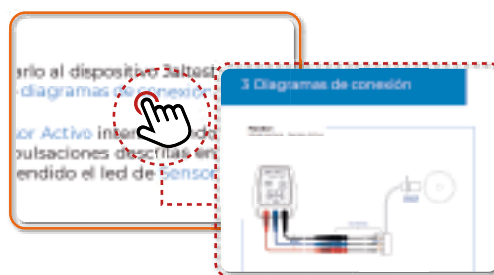
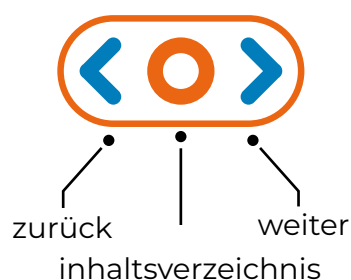

Schneller auf den Inhalt zugreifen, den Sie brauchen - mit einem Klick

# 1 Allgemeine Informationen

## 1.1 PRODUKTBESCHREIBUNG

Ausrüstung zur Reinigung von kristallisierten AdBlue/DEF-Resten im Dosiermodul, Injektorrohr und dem Injektor selbst.

## 1.2 INHALT

**1.3.** Schläuche.

**2a.** Behälter 0,4 L.

**2b.** Behälter 1,5 L.

**4.** Adapter  
Drucklufteingang  
AdBlue/DEF-Modul  
(4a und 4b).

**5.** Adapter Druckluftversorgung vom Fahrzeug zum AdBlue/DEF-Modul.

**6.** Nachfüllflasche.

**7.** Adapter für den AdBlue/DEF-Rücklauf zum Modul.

**8.** Adapter AdBlue/DEF- Eingang zum Modul.

**9.** 3/8 Zoll-Adapter für den Anschluss an die Auslass- und Rücklauf-Leitungen des AdBlue/DEF-Behälters.

**10.** 5/16 Zoll-Adapter für den Anschluss an die Auslass- und Rücklauf-Leitungen des AdBlue/DEF-Behälters.

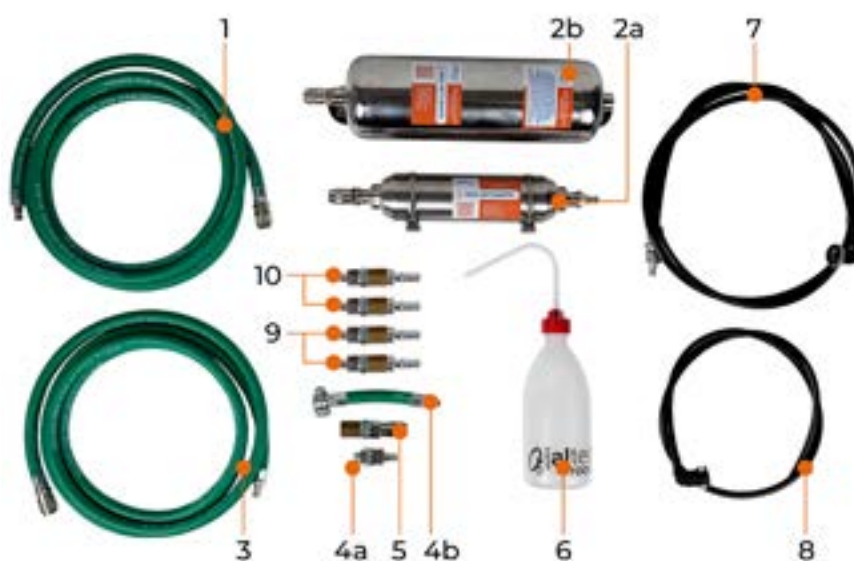

## 1.3 ANWENDUNG

- NoNOX System (MAN TGL, TGM, TGS, TGX und Euro 6 Busse mit AdBlue/DEF Emitec System).
- Emitec-AdBlue/DEF-System bei Fahrzeugen mit Cummins Motor
- Albonair-AdBlue/DEF-System (VOLVO, RENAULT, UD-Lkws und weitere Euro 6-Fahrzeuge).
- Bosch-AdBlue/DEF-System Denoxtronic 2.2 und Denoxtronic 6-HD (DAF, IVECO, MAN, andere Euro 6-Fahrzeuge, Landmaschinen, Baumaschinen, usw.)

## 1.4 SICHERHEITSVORKEHRUNGEN

Um Unfälle und/oder Verletzungen zu vermeiden, müssen folgende Sicherheitsvorkehrungen getroffen werden:

- Fahrzeug auf eine ebene Fläche stellen.
- Park-/Feststellbremse aktivieren.
- Schalthebel der Gangschaltung in Neutralstellung setzen.
- Vermeiden Sie bewegende Teile oder solche mit hohen Temperaturen.
- Tragen Sie angemessene Kleidung.



## 2 Verfahren

### 2.1 ADBLUE/DEF EMITEC SYSTEM (NONOX)

#### 2.1.1 SCHRITTE VORHER

a. Entleerungstest des AdBlue/DEF-Kreislaufs mit dem Diagnosegerät durchführen.

#### **NoNOx System >> Systemprüfungen “SYSTEM FÜLLEN UND SPÜLEN”**

b. Obere, vordere und seitliche Schutzbleche demontieren.



c. Blechstützen demontieren.



**d.** Halterung des AdBlue/DEF-Injektors demontieren und Injektor entnehmen.

- Klemme demontieren.
- Mutter des Formteils losschrauben.
- AdBlue/DEF-Injektor entfernen und an der Mutter des Formteils festschrauben.
- AdBlue/DEF-Einspritzdüse reinigen.



**Hinweis:** um die darauffolgenden Tests bequemer zu gestalten, empfehlen wir die Fixierungen des NOx-Sensors zu demontieren.

**e.** Schutzabdeckungen des AdBlue/DEF Moduls abmontieren.



## 2.1.2 REINIGUNG DES ADBLUE/DEF-AUSLASSKREISLAUFES

- a.** Für grösseren Komfort beim Abhängen oder Ausbauen druckluftführender Leitungen empfehlen wir den pneumatischen Versorgungsdruck vorher abzulassen.
- b.** Druckluft-Eingangsverbindung am AdBlue/DEF-Modul (1) abmontieren. **(1)**.

**Hinweis:** sollte das Fahrzeug Druckluft im Kreislauf haben, geht diese bei der Demontage der Verbindung verloren.



1. Drucklufteingang.
2. Elektrischer Steckverbinder/Steuerventil Druckluftstrom.
3. Elektrischer Steckverbinder/Heizung der AdBlue/DEF-Pumpe.
4. AdBlue/DEF-Einlass.
5. Auslass/Mischung von AdBlue/DEF und Luft.
6. AdBlue/DEF-Rücklauf.

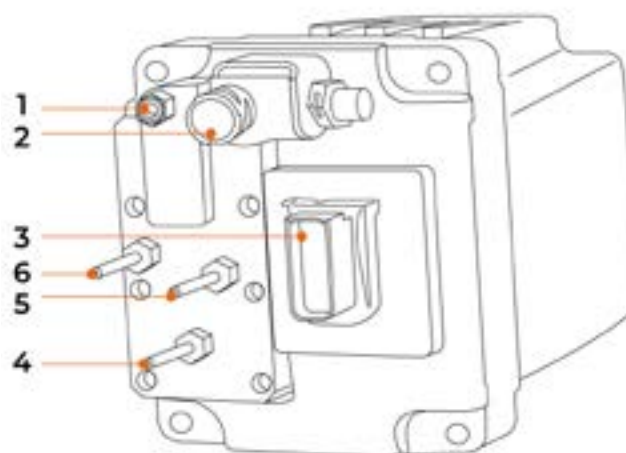

c. Adapter **"4"** (**4a** oder **4b** je nach Sachlage) und **"5"** am Drucklufteingang des AdBlue/DEF Modul (**1**) und am Druckluftausgang des Fahrzeuges anschliessen. Danach an jeden Adapter einen Schlauch (**"1"** und **"3"**) ankoppeln, aber noch nicht an den Tank **"2a"** anschliessen.

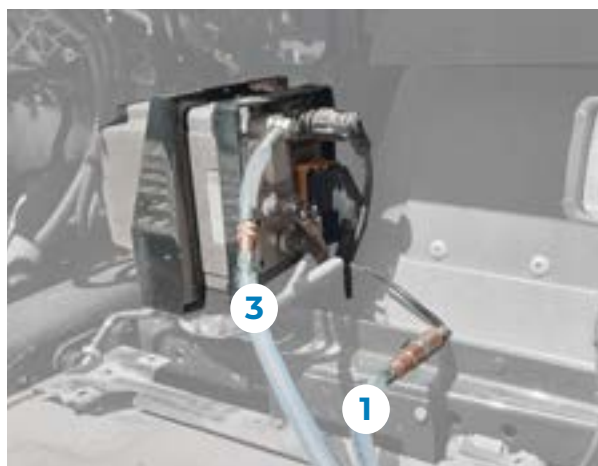

d. Tank **"2a"** von oben mit 250 ml warmen, destilliertem Wasser (MÁX. 60 °C/140 °F) füllen und dafür die Nachfüllflasche **"6"**. **benützen.**



e. Schläuche “1” und “3” an den Tank “2a” anschliessen.



f. Motor anlassen und halten bis der Druckluftkreislauf aufgeladen ist.

g. Führen Sie mit dem Diagnosewerkzeug die entsprechende Aktion so oft wie nötig durch und bis die Injektordüse nur noch Druckluft ausstösst. Benützen Sie einen Behälter oder ein Reagenzglas um die durch den Injektor ausgestossenen 250 ml Wasser aufzufangen.

### NoNOx System >> Systemprüfungen „PRÜFUNG LUFTKREISLAUF“

h. Die pneumatische Installation vor den Prüfungen wieder einbauen. Druckluft-Eingangsverbindung (1) am AdBlue/DEF-Modul montieren.

**Hinweis:** wenn der Kreislauf nicht drucklos gemacht wird, geht die Druckluft bei der Demontage dieser Verbindungen verloren.

## 2.1.3 REINIGUNG DES ADBLUE/DEF-EINLASSKREISLAUFES BEIM MODUL

a. Motor anlassen und halten, bis der Druckluftkreislauf unter Druck steht.

b. Die Verbindungen (4) und (6) des AdBlue/DEF-Moduls abhängen.

c. Einen Behälter oder ein Rohr an der Öffnung (6) ansetzen, um die Rücklaufflüssigkeit aufzufangen.

d. Schlauch “7” mit 3/8” Schnellkupplung an den AdBlue/DEF-Einfüllstutzen anschliessen (4). Das andere Ende an die Schnellkupplung am unteren Teil des Tanks “2a” anschliessen.

Der Tank muss zu Beginn leer sein und ohne die Schläuche des vorherigen Test.

e. Tank “2a” on oben mit warmem, destilliertem Wasser (MÁX. 60 °C/140 °F) nachfüllen. Bitte beachten, dass die eingegebene Menge ungefähr der dosierten Menge entspricht.

**f.** Test der durchschnittlichen Dosierung durchführen. Einen Behälter oder ein Reagenzglas verwenden, um das durch den Injektor dosierte Wasser aufzufangen.

**NoNOx System >> Systemprüfungen >> ADBLUE/DEF-DOSIERUNG >> “DURCHSCHNITTLICHE DOSIERUNG”**



## 2.1.4 SCHRITTE NACHHER

- a.** Prüfen, ob im Steuergerät keine Fehler gespeichert worden sind.
- b.** Reinigungsausrüstung des AdBlue/DEF-Moduls demontieren und mit heissen Wasser alle Komponenten inklusive dem Tank spülen.
- c.** Anschlüsse des AdBlue/DEF-Moduls montieren und Dichtheit von Modul und den Anschlüssen überprüfen.
- d.** Plastikschatz des AdBlue/DEF-Moduls montieren.
- e.** Schutzbleche montieren.

## 2.2 ADBLUE/DEF EMITEC SYSTEM (CUMMINS MOTOR)

### 2.2.1 SCHRITTE VORHER

- a. Dosiersystem der AdBlue/DEF-Flüssigkeit überprüfen
- b. Zündung ausschalten und Batterien abhängen
- c. Druck des AdBlue/DEF-Systems ablassen
- d. AdBlue/DEF-Injektor entfernen

**Hinweis:** ein entsprechendes Gefäß am Ende der Rohrleitung platzieren



### 2.2.2 REINIGUNG DES ADBLUE/DEF-AUSLASSKREISLAUFES

- a. Rücklaufleitung der AdBlue/DEF-Flüssigkeit abhängen **(6)**
- b. Luftversorgungsleitung des AdBlue/DEF-Dosiermoduls **(1)** abhängen

1. Drucklufteingang.
2. Elektrischer Steckverbinder/Steuerventil Druckluftstrom.
3. Elektrischer Steckverbinder/Heizung der AdBlue/DEF-Pumpe.
4. AdBlue/DEF-Einlass.
5. Auslass/Mischung von AdBlue/DEF und Luft.
6. AdBlue/DEF-Rücklauf.

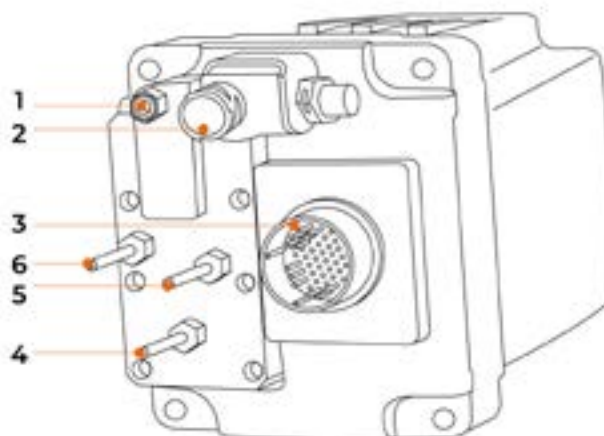

c. Adapter **"4"** (**4a** oder **4b** e nach Sachlage) und **"5"** am Drucklufteingang des Ad-Blue/DEF-Moduls (**1**) und am Druckluftausgang des Fahrzeuges anschliessen. Anschliessend an jedem Adapter einen Schlauch (**"1"** und **"3"**) anbringen, aber diese noch nicht an den Tank **"2a"** anschliessen.



d. Tank **"2a"** von oben mit 250 ml warmem, destilliertem Wasser (MÁX. 60 °C/140 °F) füllen und dafür die Füllflasche **"6"** benutzen.



e. Schlauchleitungen **"1"** y **"3"** an den Tank **"2a"** anschliessen.

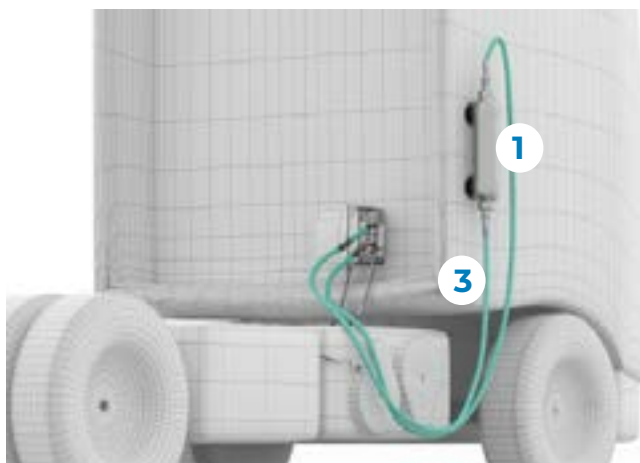



- f. Motor starten
- g. Führen Sie mit dem Diagnosewerkzeug die entsprechende Aktion so oft wie nötig durch und bis die Injektordüse nur noch Druckluft ausstösst. Benützen Sie ein Gefäss oder ein Reagenzglas, um die durch den Injektor ausgestossenen 250 ml Wasser aufzufangen.

### Komponenten betätigen >> “MAGNETVENTIL DER ADBLUE/DEF-DOSIERPUMPE”

**Hinweis:** in diesem Fall dient die angegebene Massnahme nur um die ordnungsgemäße Reinigung des AdBlue/DEF-Kreislaufs sicherzustellen.

- h. Alle abgehängten Elemente wieder anschliessen.

## 2.2.3 REINIGUNG DES ADBLUE/DEF-EINLASSKREISLAUFES BEIM MODUL

- a. AdBlue/DEF-Versorgungsleitung des Dosiermoduls (4) abhängen.
- b. Rücklaufleitung (6) der AdBlue/DEF-Flüssigkeit abhängen.
- c. Ein Gefäss oder ein Rohr an der Öffnung (6) ansetzen, um die Rücklaufflüssigkeit aufzufangen.
- d. Schlauchleitung “7” mit einer 3/8"- Schnellkupplung an den AdBlue/DEF-Einfüllstutzen anschliessen (4).



- e. Schlauchleitung an den Tank “2a” anschliessen.

Der Tank muss zu Beginn leer sein und ohne die Schläuche des vorherigen Tests.







**f.** Tank **“2a”** von oben mit 250 ml warmem, destilliertem Wasser (MÁX. 60 °C/140 °F) füllen.

**g.** Motor starten

**h.** Mit dem Diagnosewerkzeug die entsprechende Aktion durchführen und das Resultat auswerten. Ein Gefäß oder ein Reagenzglas benützen, um das durch den Injektor dosierte Wasser aufzufangen. Wenn das Wasser nicht vollständig abläuft, den Vorgang wiederholen.

### **Systemprüfungen >> “ADBLUE/DEF-PUMPE”**

**Hinweis:** in diesem Fall dient die angegebene Massnahme nur um die ordnungsgemäße Reinigung des AdBlue/DEF-Kreislaufs sicherzustellen.

**i.** Alle abgehängten Elemente wieder anschliessen.

## 2.2.4 SCHRITTE NACHHER

**a.** Prüfen, ob im Steuergerät keine Fehler gespeichert wurden.

**b.** AdBlue/DEF-Modulreinigungsausrüstung demontieren und alle Komponenten inklusive dem Tank mit warmem Wasser spülen.

**c.** Anschlüsse des AdBlue/DEF-Moduls montieren und Dichtheit von Modul und den Anschlüssen überprüfen.

## 2.3 ALBONAIR ADBLUE/DEF-SYSTEM

### 2.3.1 SCHRITTE VORHER

**a.** Spültest des AdBlue/DEF-Kreislaufs mit dem Diagnosetool durchführen.

### **ACM-System >> Systemchecks > “ADBLUE/DEF-KREISLAUF SPÜLEN”**

**b.** Schutzbleche abmontieren.



Montieren Sie für ein bequemes Arbeiten auch die Stütze des Seitenblechs ab.



**c.** Halterung des AdBlue/DEF-Injektors demontieren und Injektor entnehmen.



**d.** Gefäß bei der Einspritzdüse platzieren.



## 2.3.2 REINIGUNG DES ADBLUE/DEF-KREISLAUFS

### a. AdBlue/DEF-Anschluss ans Modul abtrennen (3).

**Hinweis:** AdBlue/DEF-Reste reinigen, die nach dem Abtrennen möglicherweise heruntergefallen sind.

- A.** AdBlue/DEF-Pumpe.
- B.** Ventil der Heizung des Tanks des AdBlue/DEF.
- C.** Temperatursensor des AdBlue/DEF / Luftregelventil.
- D.** Luftdrucksensor.
- E.** Drucksensor des AdBlue/DEF.

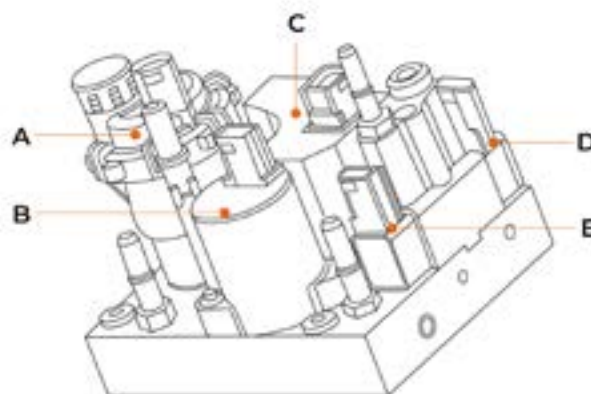

- 1.** Kühlmiteleinlass.
- 2.** Drucklufteingang.
- 3.** AdBlue/DEF-Einlass.

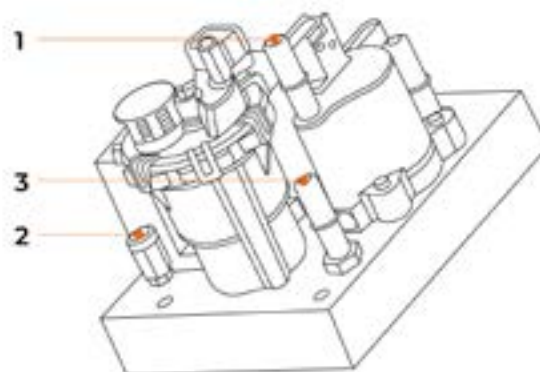

- 4.** Kühlmittelauslass.
- 5.** Luftauslass.
- 6.** AdBlue/DEF-Auslass.

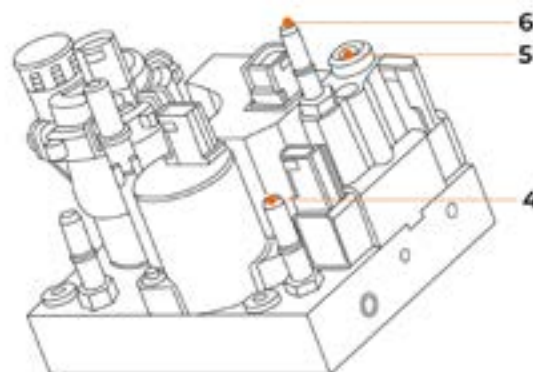



b. Schlauchleitung "7" mit einer 3/8"- Schnellkupplung an den AdBlue/DEF-Einfüllstutzen (3) anschliessen.



c. Das andere Ende der Schlauchleitung "7" an die Schnellkupplung am unteren Teil des Tanks "2a" anschliessen.

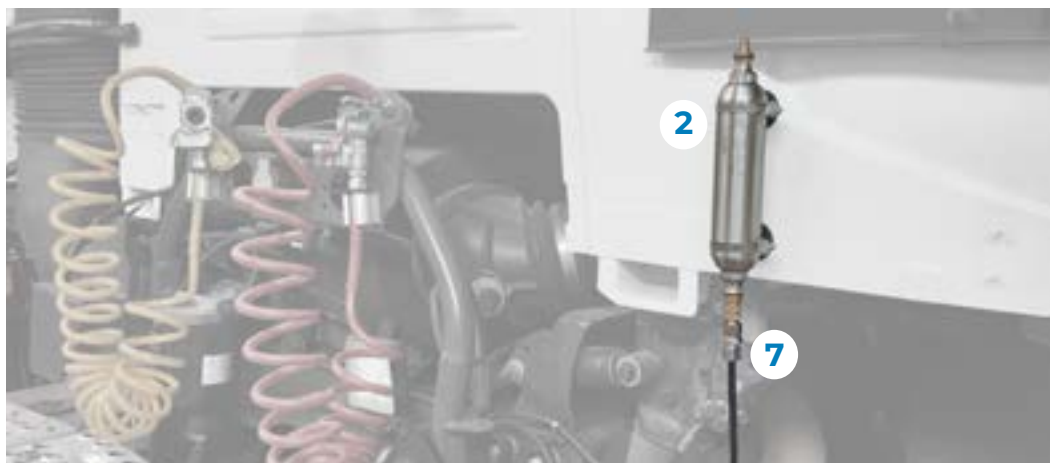

d. Tank "2a" von oben mit ungefähr 200 ml warmem, destilliertem Wasser(MÁX. 60 °C/140 °F) füllen und dafür die Füllflasche "6" benutzen.





e. Mit dem Jaltest-Diagnosetool den Reinigungstest des AdBlue/DEF-Moduls vornehmen.

### ACM-System >> Systemchecks > "REINIGUNG ADBLUE/DEF-MODUL"

**Hinweis:** Damit der AdBlue/DEF-Kreislauf als nicht verstopft und das System als korrekt funktionierend betrachtet werden kann, muss die dosierte Wassermenge zwischen den am Ende der Aktion angegebenen Höchst- und Mindestwerten liegen.

## 2.3.3 SCHRITTE NACHHER

- a. Prüfen, ob im Steuergerät keine Fehler gespeichert worden sind.
- b. Diagnosewerkzeug und Zündung ausschalten.
- c. Reinigungs-ausrüstung des AdBlue/DEF-Moduls demontieren und alle Komponente inklusive Tank mit heissem Wasser spülen.
- d. Anschluss des AdBlue/DEF-Moduls montieren und Dichtheit von Modul und den Anschlüssen überprüfen.
- e. AdBlue/DEF-Injektor montieren.
- f. Schutzbleche montieren.

## 2.4 BOSCH-ADBLUE/DEF-SYSTEM DENOXTRONIC 2.2 UND DENOXTRONIC 6-HD

### 2.4.1 SCHRITTE VORHER

- a. AdBlue/DEF-Kreislauf luftspülen.

**Hinweis:** Zündung ausschalten und 2 Minuten warten bis Sie sie wieder einschalten.



**b.** Lokalisieren Sie das AdBlue/DEF-Dosiermodul.

**Hinweis:** Je nach Fahrzeug ist der Standort unterschiedlich.

**c.** Gegebenenfalls Schutzbleche ausbauen.

**d.** Halterung der AdBlue/DEF-Einspritzdüse ausbauen und Einspritzdüse entfernen.

**Hinweis:** Je nach Fahrzeug ist der Standort unterschiedlich.



**e.** An der Düse der Einspritzdüse ein Gefäß anbringen.

## 2.4.2 REINIGUNG DES ADBLUE/DEF-KREISLAUFS

**a.** Trennen Sie die AdBlue/DEF-Zuleitung am Dosiermodul **(6)** ab.

**Hinweis:** Reinigen Sie eventuelle während des Abtrennens auf den Boden gefallene AdBlue/DEF-Rückstände.

**b.** Rücklaufleitung **(4)** der AdBlue/DEF-Flüssigkeit zum Behälter abtrennen.

- 1.** AdBlue/DEF-Auslass.
- 2.** Kühlmittelauslass.
- 3.** Kühlmittleinlass.
- 4.** AdBlue/DEF-Rücklauf.
- 5.** Stromanschluss.
- 6.** AdBlue/DEF-Einlass.

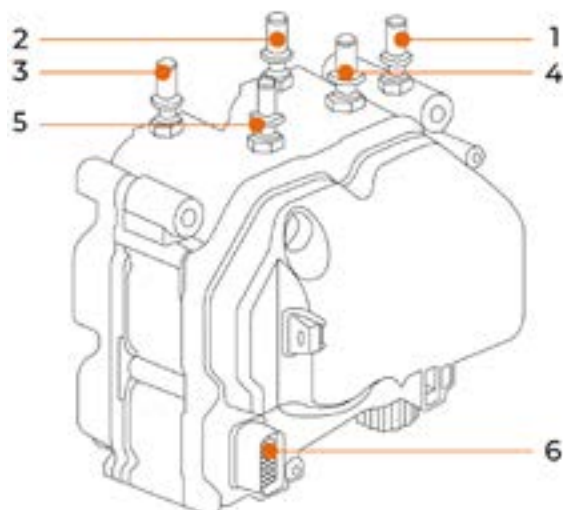

c. Den Schlauch "7" mit einer 3/8-Zoll-Schnellkupplung an den AdBlue/DEF-Einfüllstutzen anschliessen (6).

d. Den Adapter "8" an den AdBlue/DEF-Rücklaufstutzen (4) anschliessen und ein Gefäss an das freie Ende stellen.

**Hinweis:** Während des Tests und je nach Fahrzeug kann die Menge des zurückgelaufenen Wassers ca. 700 ml erreichen.



e. Schliessen Sie nun das andere Ende von Schlauch "7" an die Schnellkupplung am Unterteil von Behälter "2b" an.

**Hinweis:** Der Behälter muss höher als bzw. oberhalb des AdBlue/DEF-Einlass vom Dosiermodul gestellt werden.



f. Füllen Sie den Behälter "2b" von oben mit heissem, destilliertem Wasser (Max. 60 °C/140 °F). Benützen Sie dazu die Füllflasche "6".



**g.** Führen Sie den Reinigungstest des AdBlue/DEF-Moduls mit dem Diagnosetool durch.

### **Wartung >> “REINIGUNG DES ADBLUE/DEF-MODULS”**

**Hinweis:** Um sicher zu gehen, dass der AdBlue/DEF-Kreislauf nicht verstopft ist und dass das System ordnungsgemäss funktioniert, muss die dosierte Wassermenge nach dem Test im Bereich der angezeigten Höchst- und Mindestwerte liegen.

## 2.4.3 SCHRITTE NACHHER

**a.** Prüfen, ob im Steuergerät keine Fehler gespeichert worden sind.

**b.** Trennen Sie Schlauch “7” am Unterteil von Behälter “2b” ab.

**c.** Diagnosetool und Zündung ausschalten.

**Wichtig:** Das System muss vor Beginn des nächsten Schritts das in den Schlauchleitungen verbleibende Wasser automatisch ausstossen.

**d.** Demontieren Sie die AdBlue/DEF-Modul-Reinigungs-ausrüstung und spülen Sie alle Komponenten einschliesslich des Behälters gründlich mit heissem Wasser.

**e.** Montieren Sie nun alle in den vorherigen Schritten ausgebauten Komponente.



# ●.cojali

Jaltest.com  
cojali.com

2023 V.1 DE



Local Distributor



**Kit per la pulizia del modulo di  
AdBlue/DEF**

Manuale utente

[jaltest.com](http://jaltest.com)

**cojali**  
INNOVATION & TECHNOLOGY



Rev. 01



## Kit per la pulizia del modulo di AdBlue/DEF

Manuale utente



# Indice

Indice	3
Informazioni generali	4
1.1 DESCRIZIONE DEL PRODOTTO	4
1.2 CONTENUTO	4
1.3 APPLICAZIONE	4
1.4 PRECAUZIONI DI SICUREZZA	5
Procedimento	6
2.1 SISTEMA ADBLUE/DEF EMITEC (NONOX)	6
2.1.1 PASSAGGI PRECEDENTI	6
2.1.2 PULIZIA DEL CIRCUITO DI USCITA DI ADBLUE/DEF	7
2.1.3 PULIZIA DEL CIRCUITO DI ENTRATA DI ADBLUE/DEF	9
2.1.4 PASSAGGI SUCCESSIVI	10
2.2 SISTEMA ADBLUE/DEF EMITEC (MOTORE CUMMINS)	11
2.2.1 PASSAGGI PRECEDENTI	11
2.2.2 PULIZIA DEL CIRCUITO DI USCITA DI ADBLUE/DEF	11
2.2.3 PULIZIA DEL CIRCUITO DI ENTRATA DI ADBLUE/DEF	13
2.2.4 PASSAGGI SUCCESSIVI	14
2.3 SISTEMA ADBLUE/DEF ALBONAIR	14
2.3.1 PASSAGGI PRECEDENTI	14
2.3.2 PULIZIA DEL CIRCUITO DI ADBLUE/DEF	16
2.3.3 PASSAGGI SUCCESSIVI	18
2.4 SISTEMA ADBLUE/DEF BOSCH DENOXTRONIC 2.2 E DENOXTRONIC 6-HD	18
2.4.1 PASSAGGI PRECEDENTI	18
2.4.2 PULIZIA DEL CIRCUITO DI ADBLUE/DEF	19
2.4.3 PASSAGGI SUCCESSIVI	21

## Navigazione facilitata



# 1 Informazioni generali

## 1.1 DESCRIZIONE DEL PRODOTTO

Strumento per effettuare la pulizia dei residui di AdBlue/DEF cristallizzati nel modulo di dosaggio, nel condotto degli iniettori e negli iniettori stessi.

## 1.2 CONTENUTO

**1.3.** Tubi.

**2.** Serbatoio 0,4 L.

**3.** Serbatoio 1,5 L.

**4.** Adattatore per il collegamento dell'entrata dell'aria compressa al modulo di AdBlue/DEF. (4a e 4b).

**5.** Adattatore per il collegamento dell'alimentazione dell'aria compressa dal veicolo al modulo di AdBlue/DEF.

**6.** Bottiglia per il rabbocco

**7.** Adattatore per l'entrata di AdBlue/DEF nel modulo.

**8.** Adattatore per il ritorno di AdBlue/DEF nel modulo.

**9.** Adattatori da 3/8" per connessioni nei tubi di uscita e di ritorno del serbatoio di AdBlue/DEF.

**10.** Adattatori da 5/16" per connessioni nei tubi di uscita e di ritorno del serbatoio di AdBlue/DEF.

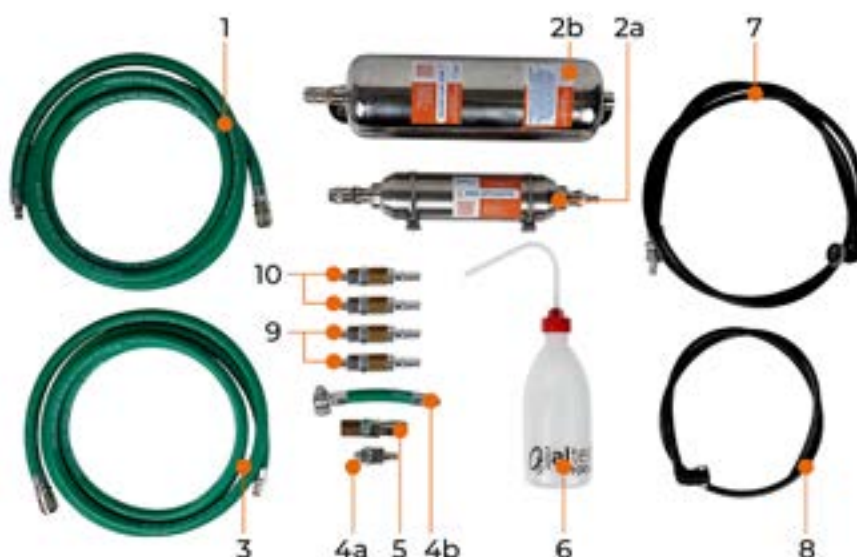

## 1.3 APPLICAZIONE

-Sistema NoNOX (MAN TGL, TGM, TGS, TGX e autobus Euro 6 con il sistema AdBlue/DEF Emitec).

-Sistema AdBlue/DEF Emitec in veicoli con motore Cummins.

-Sistema AdBlue/DEF Albonair (VOLVO, RENAULT, UD Trucks e altri veicoli Euro 6).

-Sistema AdBlue/DEF Bosch Denoxtronic 2.2 e Denoxtronic 6-HD (DAF, IVECO, MAN, altri veicoli Euro 6, macchine agricole, macchine edili, ecc.).

## 1.4 PRECAUZIONI DI SICUREZZA

Bisogna tenere in considerazione le seguenti precauzioni di sicurezza per evitare incidenti e/o lesioni:

- Collocare il veicolo su una superficie piana.
- Inserire il freno di stazionamento.
- Posizionare la leva del cambio in folle o posizione neutra.
- Evitare il contatto con componenti che possono essere caldi o in movimento.
- Utilizzare un abbigliamento adeguato.

## 2 Procedimento

### 2.1 SISTEMA ADBLUE/DEF EMITEC (NONOX)

#### 2.1.1 PASSAGGI PRECEDENTI

**a.** Effettuare la prova di scarico del circuito di AdBlue/DEF con lo strumento di diagnosi.

**Sistema NoNOx >> Verifica del sistema “CARICO E SPURGO DEL SISTEMA”**

**b.** Smontare le lamiere protettrici superiori, frontali e laterali.



**c.** Smontare i supporti delle piastre.



**d.** Smontare il supporto dell'iniettore di AdBlue/DEF ed estrarre l'iniettore.

- Smontare la fascetta.
- Svitare il dado del raccordo.
- Estrarre l'iniettore di AdBlue/DEF e riavvitarlo nel dado del raccordo.
- Pulire il getto dell'iniettore di AdBlue/DEF.



**Nota:** per una maggiore comodità durante le prove successive, smontare il fissaggio del sensore NOx.

**e.** Smontare le protezioni del modulo di AdBlue/DEF.



## 2.1.2 PULIZIA DEL CIRCUITO DI USCITA DI ADBLUE/DEF

**a.** Per una maggiore comodità al momento di scollegare o smontare i circuiti dell'aria compressa, scaricare la pressione di alimentazione pneumatica.

**b.** Smontare il raccordo di entrata dell'aria compressa al modulo di AdBlue/DEF (1).

**Nota:** una volta smontato il raccordo, l'eventuale aria compressa presente nel circuito verrà persa.





1. Entrata dell'aria compressa.
2. Connettore elettrico/Valvola di controllo del flusso dell'aria compressa.
3. Connettore elettrico/Riscaldamento della pompa AdBlue/DEF.
4. Entrata di AdBlue/DEF.
5. Uscita/Miscela di AdBlue/DEF e aria
6. Ritorno di AdBlue/DEF.

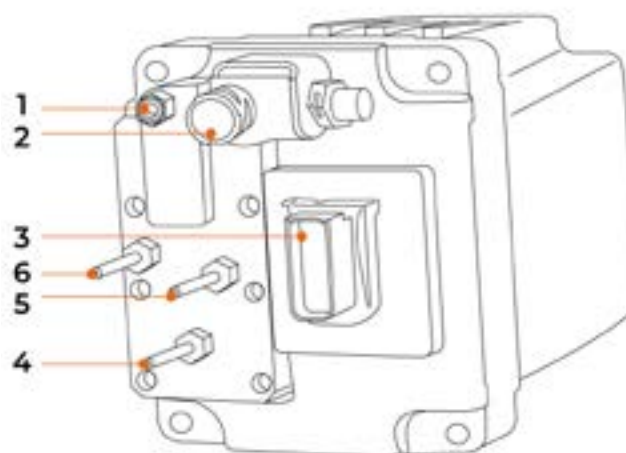

**c.** Connettere gli adattatori “4” (4a o 4b a seconda dei casi) e “5” nell'entrata dell'aria compressa del modulo di AdBlue/DEF (1) e nell'uscita dell'aria compressa del veicolo. In seguito, accoppiare un tubo (“1” e “3”) a ogni adattatore, ma non collegarli al serbatoio “2”.

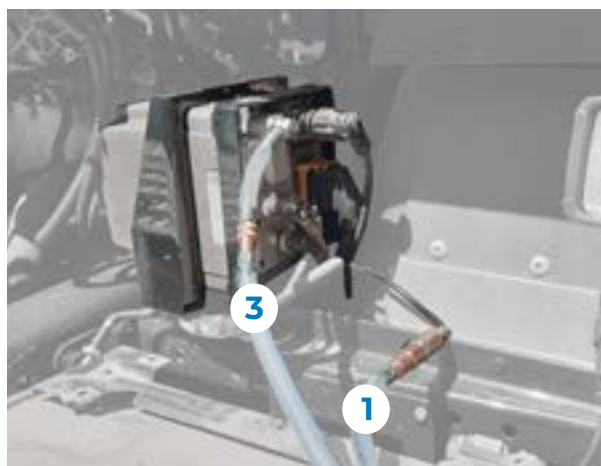

**d.** Riempire il serbatoio “2” dalla parte superiore con 250 ml di acqua distillata calda (MAX. 60 °C/140 °F) utilizzando la bottiglia per il rabbocco “6”.





e. Collegare i tubi “1” e “3” al serbatoio “2a”.



f. Avviare il motore e mantenerlo acceso fino a caricare il circuito di aria compressa.

g. Eseguire l'azione corrispondente con lo strumento di diagnosi e ripetere l'operazione fino a quando dall'ugello dell'iniettore uscirà solamente aria compressa. Utilizzare un recipiente o una provetta per raccogliere i 250 ml circa di acqua espulsi dall'iniettore.

### **Sistema NoNox >> Verifica del sistema “TEST DEL CIRCUITO DELL'ARIA”**

h. Ripristinare l'installazione pneumatica precedente alle prove. Montare il raccordo (1) di entrata dell'aria compressa nel modulo di AdBlue/DEF.

**Nota:** una volta smontati i raccordi, se non si depressurizza il circuito di aria compressa, quest'aria compressa verrà persa.

## 2.1.3 PULIZIA DEL CIRCUITO DI ENTRATA DI ADBLUE/DEF

a. Avviare il motore e mantenerlo acceso fino a pressurizzare il circuito di aria compressa.

b. Scollegare i raccordi (4) e (6) del modulo di AdBlue/DEF.

c. Collocare un recipiente o un tubo nella bocca (6) per raccogliere il liquido di ritorno.

d. Collegare il tubo “7” con raccordo rapido da 3/8” al raccordo di entrata dell'AdBlue/DEF (4). Collegare l'altra estremità al raccordo rapido nella parte inferiore del serbatoio “2a”.

Prima di iniziare il processo, il serbatoio deve essere vuoto e senza i tubi delle prove precedenti.

e. Riempire il serbatoio “2a” con acqua distillata calda (MAX. 60 °C/140 °F) dalla parte superiore. Bisogna tenere a mente che la quantità di acqua introdotta sarà all'incirca quella che viene dosata.

**f.** Avviare la verifica di dosaggio medio. Utilizzare un recipiente o una provetta per raccogliere l'acqua dosata dall'iniettore.

**Sistema NoNOx >> Verifiche del sistema >> DOSAGGIO DEL ADBLUE/DEF >> "DOSAGGIO MEDIO"**



## 2.1.4 PASSAGGI SUCCESSIVI

- a.** Assicurarsi che non ci siano errori memorizzati nell'Unità di Controllo.
- b.** Smontare lo strumento di pulizia dal modulo di AdBlue/DEF e sciacquare con acqua calda tutti i componenti, incluso il serbatoio.
- c.** Montare le connessioni del modulo di AdBlue/DEF e verificare la tenuta sia del modulo che delle connessioni.
- d.** Montare le protezioni di plastica del modulo di AdBlue/DEF.
- e.** Montare le lamiere di protezione.

## 2.2 SISTEMA ADBLUE/DEF EMITEC (MOTORE CUMMINS)

### 2.2.1 PASSAGGI PRECEDENTI

- a. Verificare il sistema di dosaggio del liquido AdBlue/DEF
- b. Spegnere il quadro e scollegare le batterie
- c. Rilasciare la pressione del sistema di dosaggio di AdBlue/DEF
- d. Rimuovere l'iniettore di AdBlue/DEF

**Nota:** posizionare un recipiente adeguato all'estremità del tubo



### 2.2.2 PULIZIA DEL CIRCUITO DI USCITA DI ADBLUE/DEF

- a. Scollegare la tubazione di ritorno del liquido AdBlue/DEF **(6)**
- b. Scollegare la linea di alimentazione dell'aria del modulo di dosaggio di AdBlue/DEF **(1)**

1. Entrata dell'aria compressa.
2. Connettore elettrico/Valvola di controllo del flusso dell'aria compressa.
3. Connettore elettrico/Riscaldamento della pompa AdBlue/DEF.
4. Entrata di AdBlue/DEF.
5. Uscita/Miscela di AdBlue/DEF e aria
6. Ritorno di AdBlue/DEF.

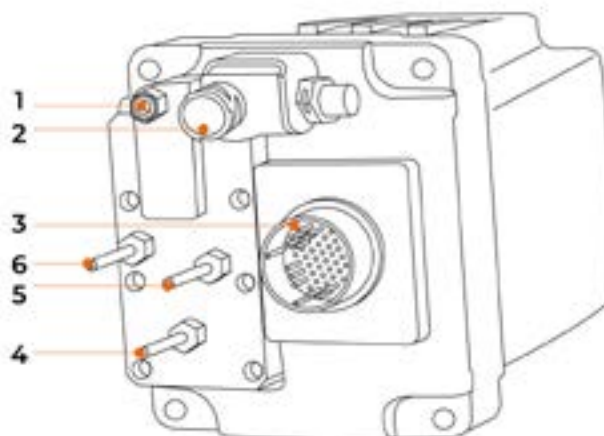



**c.** Connettere gli adattatori **"4"** (4a o 4b a seconda dei casi) e **"5"** nell'entrata dell'aria compressa del modulo di AdBlue/DEF (1) e nell'uscita dell'aria compressa del veicolo. In seguito, accoppiare un tubo (**"1"** e **"3"**) a ogni adattatore, ma non collegarli al serbatoio **"2a"**.



**d.** Riempire il serbatoio **"2a"** dalla parte superiore con 250 ml di acqua distillata calda (MAX. 60 °C/140 °F) utilizzando la bottiglia per il rabbocco **"6"**.



**e.** Collegare i tubi **"1"** e **"3"** al serbatoio **"2a"**

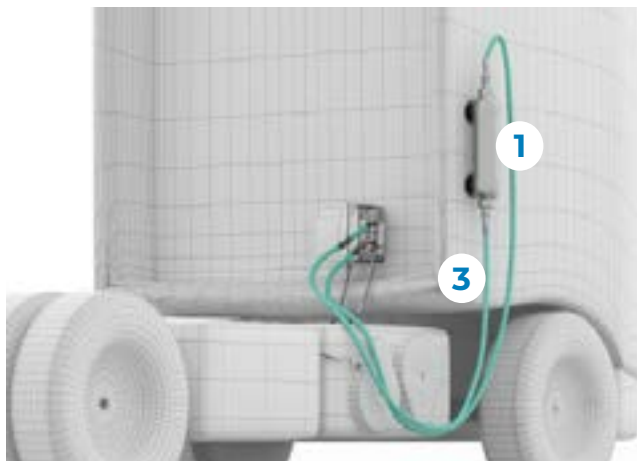



**f.** Avviare il motore

**g.** Eseguire l'azione corrispondente con lo strumento di diagnosi e ripetere l'operazione fino a quando dall'ugello dell'iniettore uscirà solamente aria compressa. Utilizzare un recipiente o una provetta per raccogliere i 250 ml circa di acqua espulsi dall'iniettore.

### **Attivazione componenti >> "ELETTRIVALVOLA DELLA POMPA DI DOSAGGIO DI ADBLUE/DEF"**

**Note:** in questo caso, l'azione indicata serve unicamente a garantire la corretta pulizia del circuito di AdBlue/DEF

**h.** Ricollegare tutti gli elementi precedentemente scollegati.

## 2.2.3 PULIZIA DEL CIRCUITO DI ENTRATA DI ADBLUE/DEF

**a.** Scollegare la tubazione di alimentazione di AdBlue/DEF del modulo di dosaggio **(4)**.

**b.** Scollegare la tubazione di ritorno del liquido AdBlue/DEF **(6)**.

**c.** Posizionare un recipiente o un tubo nella bocca **(6)** per raccogliere il liquido di ritorno.

**d.** Collegare il tubo **"7"** con il raccordo rapido da 3/8" al raccordo di entrata dell'AdBlue/DEF **(4)**.



**e.** Collegare il tubo al serbatoio **"2a"**.

Prima di iniziare il processo, il serbatoio deve essere vuoto e senza i tubi delle prove precedenti.





**f.** Riempire il serbatoio “2a” dalla parte superiore con 250 ml di acqua distillata calda (MAX. 60 °C/140 °F)

**g.** Avviare il motore

**h.** Eseguire l'azione corrispondente con lo strumento di diagnosi e valutare il risultato. Utilizzare un recipiente o una provetta per raccogliere l'acqua dosata dall'iniettore. Se l'acqua non viene drenata completamente, ripetere l'operazione.

### **Controlli del sistema >> “POMPA ADBLUE/DEF”**

**Nota:** in questo caso, l'azione indicata serve unicamente a garantire la corretta pulizia del circuito di AdBlue/DEF

**i.** Ricollegare tutti gli elementi precedentemente scollegati.

## 2.2.4 PASSAGGI SUCCESSIVI

**a.** Assicurarsi che non ci siano errori memorizzati nell'Unità di Controllo.

**b.** Smontare lo strumento di pulizia dal modulo di AdBlue/DEF e sciacquare con acqua calda tutti i componenti, incluso il serbatoio.

**c.** Montare le connessioni del modulo di AdBlue/DEF e verificare la tenuta sia del modulo che delle connessioni.

## 2.3 SISTEMA ADBLUE/DEF ALBONAIR

### 2.3.1 PASSAGGI PRECEDENTI

**a.** Effettuare la prova di spurgo del circuito di AdBlue/DEF con lo strumento di diagnosi.

### **Sistema ACM >> Verifiche del sistema >> “SPURGO DEL CIRCUITO DI ADBLUE/DEF”**

**b.** Smontare le lamiere protettive.



Per una comodità maggiore durante il processo, smontare anche il supporto laterale della lamiera.



**c.** Smontare il supporto dell'iniettore di AdBlue/DEF ed estrarre l'iniettore.



**d.** Posizionare un recipiente nell'ugello dell'iniettore.





## 2.3.2 PULIZIA DEL CIRCUITO DI ADBLUE/DEF

**a.** Scollegare il raccordo di entrata di AdBlue/DEF al modulo **(3)**.

**Nota:** pulire i residui di AdBlue/DEF che potrebbero cadere in seguito allo scollegamento.

- A.** Pompa AdBlue/DEF.
- B.** Valvola di riscaldamento del serbatoio di AdBlue/DEF.
- C.** Sensore di temperatura di AdBlue/DEF / Valvola di controllo dell'aria.
- D.** Sensore di pressione dell'aria.
- E.** Sensore di pressione di AdBlue/DEF (Diesel Exhaust Fluid).

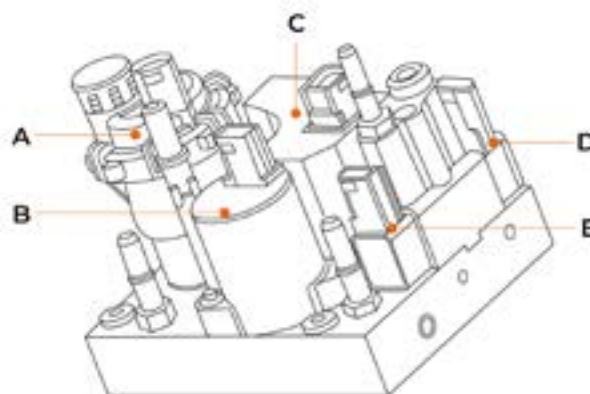

- 1.** Entrata del liquido refrigerante.
- 2.** Entrata dell'aria compressa.
- 3.** Entrata di AdBlue/DEF.

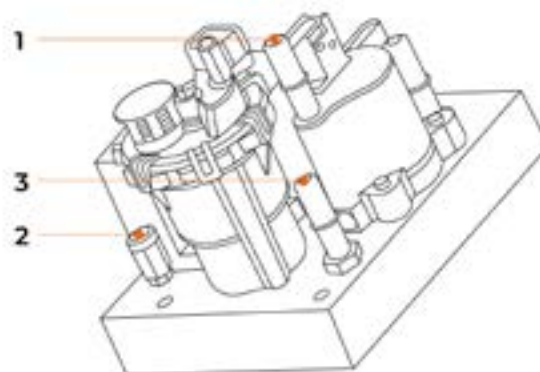

- 4.** Uscita del liquido refrigerante.
- 5.** Uscita dell'aria.
- 6.** Uscita di AdBlue/DEF.

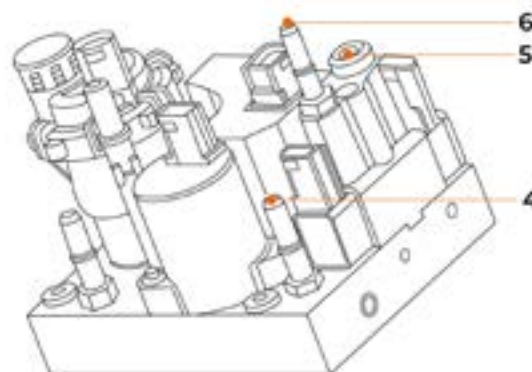



**b.** Collegare il tubo “7” con l’attacco rapido da 3/8” al raccordo di entrata dell’AdBlue/DEF **(3)**.



**c.** Collegare l’altra estremità del tubo “7” all’attacco rapido della parte inferiore del serbatoio “2a”.

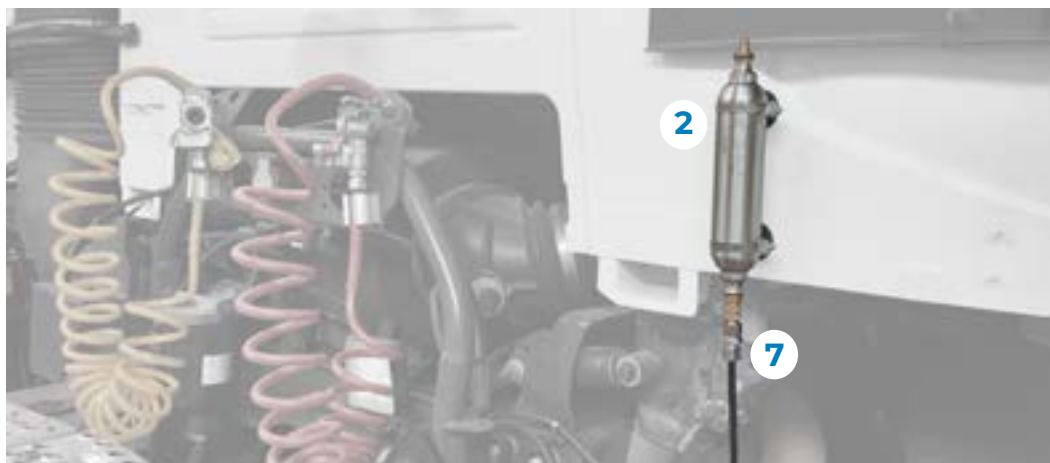

**d.** Riempire il serbatoio “2a” dalla parte superiore con 200 ml circa di acqua distillata calda (MAX. 60 °C/140 °F), utilizzando la bottiglia per il rabbocco “6”.





e. Eseguire con lo strumento di diagnosi la verifica della pulizia del modulo di AdBlue/DEF.

### **Sistema ACM >> Verifiche del sistema >> “PULIZIA DEL MODULO DI ADBLUE/DEF”**

**Nota:** per assicurarsi che il circuito di AdBlue/DEF non sia ostruito e che il sistema funzioni correttamente, il volume di acqua dosato deve essere compreso tra i valori massimi e minimi mostrati quando si termina l'azione.

## 2.3.3 PASSAGGI SUCCESSIVI

- a. Assicurarsi che non ci siano errori memorizzati nell'Unità di Controllo.
- b. Scollegare lo strumento di diagnosi e spegnere il quadro del veicolo.
- c. Smontare lo strumento di pulizia del modulo di AdBlue/DEF e sciacquare con acqua calda tutti i componenti, incluso il serbatoio.
- d. Montare la connessione del modulo di AdBlue/DEF e verificare la tenuta sia del modulo che delle connessioni.
- e. Montare l'iniettore di AdBlue/DEF.
- f. Montare le lamiera protettive.

## 2.4 SISTEMA ADBLUE/DEF BOSCH DENOXTRONIC 2.2 E DENOXTRONIC 6-HD

### 2.4.1 PASSAGGI PRECEDENTI

- a. Spurgare il circuito di AdBlue/DEF.

**Nota:** spegnere il quadro e attendere 2 minuti prima di riaccenderlo.



**b.** Localizzare il modulo di dosaggio di AdBlue/DEF.

**Nota:** l'ubicazione varia in base al veicolo.

**c.** Smontare le lamiere protettive se necessario

**d.** Smontare il supporto dell'iniettore di AdBlue/DEF ed estrarre l'iniettore.

**Nota:** l'ubicazione varia in base al veicolo.



**e.** Posizionare un recipiente nell'ugello dell'iniettore.

## 2.4.2 PULIZIA DEL CIRCUITO DI ADBLUE/DEF

**a.** Scollegare il tubo di alimentazione di AdBlue/DEF del modulo di dosaggio **(6)**.

**Nota:** pulire i residui di AdBlue/DEF che potrebbero cadere durante lo scollegamento.

**b.** Scollegare il tubo di ritorno del liquido AdBlue/DEF verso il serbatoio **(4)**.

- 1.** Uscita di AdBlue/DEF.
- 2.** Uscita del liquido refrigerante.
- 3.** Entrata del liquido refrigerante.
- 4.** Ritorno di AdBlue/DEF.
- 5.** Connettore elettrico.
- 6.** Entrata di AdBlue/DEF.

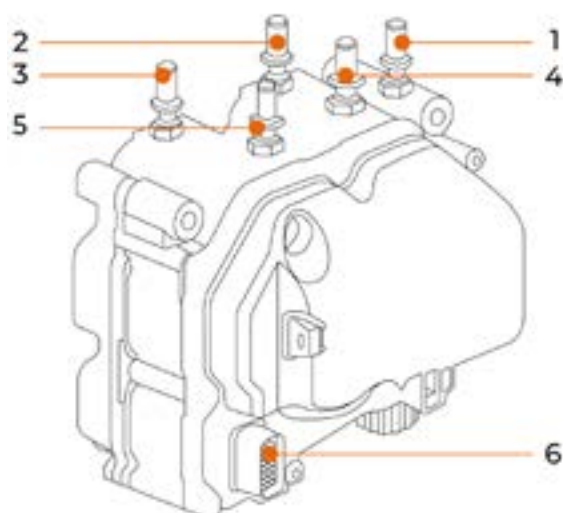

**c.** Collegare il tubo “7” con l’attacco rapido da 3/8” al perno di entrata di AdBlue/DEF (6).

**d.** Collegare l’adattatore “8” al perno di ritorno di AdBlue/DEF (4) e posizionare un recipiente nell’estremità libera.

**Nota:** durante la prova, e in base al veicolo, il volume dell’acqua di ritorno può raggiungere i 700 ml circa.



**e.** Collegare l’altra estremità del tubo “7” all’attacco rapido della parte inferiore del serbatoio “2b”.

**Nota:** fissare il serbatoio a un’altezza superiore a quella della presa di entrata di AdBlue/DEF del modulo di dosaggio.



**f.** Riempire il serbatoio “2b” dalla parte superiore con acqua distillata calda (MAX. 60 °C/140 °F) utilizzando la bottiglia per il rabbocco “6”.



**g.** Con lo strumento di diagnosi, eseguire l'azione di pulizia del modulo di AdBlue/DEF.

### **Manutenzione >> "PULIZIA DEL MODULO DI ADBLUE/DEF"**

**Nota:** per assicurarsi che il circuito di AdBlue/DEF non sia ostruito e che il sistema funzioni correttamente, il volume di acqua dosato deve essere compreso tra i valori massimi e minimi mostrati quando si termina l'azione.

## 2.4.3 PASSAGGI SUCCESSIVI

**a.** Assicurarsi che non ci siano errori memorizzati nell'unità di controllo.

**b.** Scollegare il tubo "7" dalla parte inferiore del serbatoio "2b".

**c.** Scollegare lo strumento di diagnosi e spegnere il quadro del veicolo.

**Importante:** il sistema deve espellere automaticamente l'acqua restante dai tubi prima di continuare con il passaggio successivo.

**d.** Smontare lo strumento di pulizia del modulo di AdBlue/DEF e sciacquare con acqua calda tutti i componenti, incluso il serbatoio.

**e.** Assemblare tutti i componenti smontati nei passaggi precedenti.

# cojali

Jaltest.com  
cojali.com

2023 V.1 IT



Local Distributor



**Kit para limpeza do módulo  
de AdBlue/DEF**

Manual de usuário

[jaltest.com](http://jaltest.com)





Rev. 01



## Kit para limpeza do módulo de AdBlue/DEF

Manual de usuário



# Índice

Índice	3
Informação geral	4
1.1 DESCRIÇÃO DO PRODUTO	4
1.2 CONTEÚDO	4
1.3 APLICATIVO	4
1.4 PRECAUÇÕES DE SEGURANÇA	5
Procedimento	6
2.1 PASSOS ANTERIORES	6
2.1.1 PASSOS ANTERIORES	6
2.1.2 LIMPEZA DO CIRCUITO DE SAÍDA DE ADBLUE/DEF	7
2.1.3 LIMPEZA DO CIRCUITO DE ENTRADA DE ADBLUE/DEF PARA O MÓDULO	9
2.1.4 PASSOS SEGUINTE	10
2.2 SISTEMA ADBLUE/DEF EMITEC (MOTOR CUMMINS)	11
2.2.1 PASSOS ANTERIORES	11
2.2.2 LIMPEZA DO CIRCUITO DE SAÍDA DE ADBLUE/DEF	11
2.2.3 LIMPEZA DO CIRCUITO DE ENTRADA DE ADBLUE/DEF PARA O MÓDULO	13
2.2.4 PASSOS SEGUINTE	14
2.3 SISTEMA ADBLUE/DEF ALBONAIR	14
2.3.1 PASSOS ANTERIORES	14
2.3.2 LIMPEZA DO CIRCUITO DE ADBLUE/DEF	16
2.3.3 PASSOS SEGUINTE	18
2.4 SISTEMA ADBLUE/DEF BOSCH DENOXTRONIC 2.2 Y DENOXTRONIC 6-HD	18
2.4.1 PASSOS ANTERIORES	18
2.4.2 LIMPEZA DO CIRCUITO DE SAÍDA DE ADBLUE/DEF	19
2.4.3 PASSOS SEGUINTE	21

## Navegação fácil

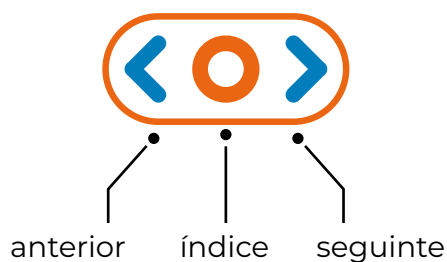

Acceda mais rápido ao conteúdo de que você precisa fazendo clic

# 1 Informação geral

## 1.1 DESCRIÇÃO DO PRODUTO

Equipamento para limpeza de restos de AdBlue/DEF cristalizado no módulo de dosagem, no duto do injetor e no próprio injetor.

## 1.2 CONTEÚDO

**1.3.** Mangueiras.

**2.** Depósito 0,4 L.

**3.** Depósito 1,5 L.

**4.** Adaptador para conexão de entrada de ar comprimido ao módulo de AdBlue/DEF. (4a e 4b).

**5.** Adaptador para conexão de alimentação de ar comprimido do veículo ao módulo de AdBlue/DEF.

**6.** Garrafa de enchimento.

**7.** Adaptador para entrada de AdBlue/DEF para o módulo.

**8.** Adaptador para retorno de AdBlue/DEF ao módulo.

**9.** Adaptadores de 3/8" para ligação nos tubos de saída e retorno do depósito de AdBlue/DEF.

**10.** Adaptadores de 5/16" para ligação nos tubos de saída e retorno do depósito de AdBlue/DEF.

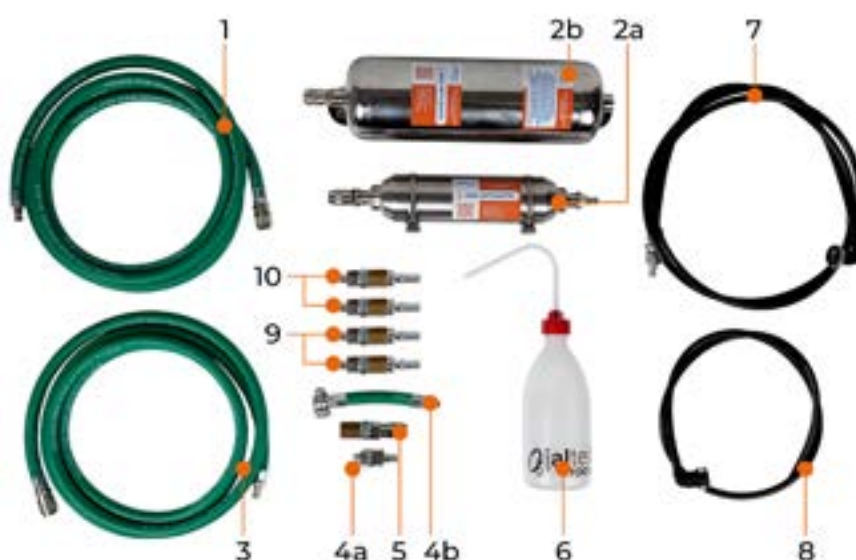

## 1.3 APLICATIVO

- Sistema NoNOX (MAN TGL, TGM, TGS, TGX e autocarros Euro 6 com sistema AdBlue Emitec).
- Sistema AdBlue/DEF Emitec em veículos com motor Cummins.
- Sistema AdBlue/DEF Albonair (VOLVO, RENAULT, UD Trucks e outros veículos Euro 6).
- Sistema AdBlue/DEF Bosch Denoxtronic 2.2 e Denoxtronic 6-HD (DAF, IVECO, MAN, outros veículos Euro 6, máquinas agrícolas, máquinas de construção, etc.).

## 1.4 PRECAUÇÕES DE SEGURANÇA

As seguintes precauções de segurança devem ser levadas em consideração para evitar acidentes e/ou lesões:

- Coloque o veículo em uma superfície plana.
- Ative o freio de estacionamento.
- Coloque a alavanca de mudança de marchas na em ponto morto ou posição neutra.
- Evite o contato com peças que possam estar a altas temperaturas ou em movimento.
- Use roupas de trabalho adequadas.



## 2 Procedimento

### 2.1 PASSOS ANTERIORES

#### 2.1.2 PASSOS ANTERIORES

**a.** Realizar o teste de drenagem do circuito de AdBlue/DEF com a ferramenta de diagnóstico.

**Sistema NoNOx >> Verificações do sistema “ENCHIMENTO E PURGA DO SISTEMA”**

**b.** Desmontar as placas de proteção superior, frontal e lateral.



**c.** Desmontar os suportes das placas.





**d.** Desmontar o suporte do injetor de AdBlue/DEF e remover o injetor.

- Remover a braçadeira.
- Desaparafusar a porca de união.
- Remover o injetor de Adblue/DEF e voltar a aparafusar na porca de união.
- Limpar o bico do injetor de AdBlue/DEF.



**Nota:** para maior comodidade durante os testes subsequentes, remover as montagens do sensor NOx.

**e.** Desmontar as proteções do módulo de AdBlue/DEF.



## 2.1.2 LIMPEZA DO CIRCUITO DE SAÍDA DE ADBLUE/DEF

- a.** Aliviar a pressão de alimentação pneumática para maior comodidade ao desconectar ou remover linhas através das quais o ar comprimido está fluindo.
- b.** Desmontar a união de entrada de ar comprimido para o módulo de AdBlue/DEF **(1)**.

**Obs:** se o veículo tiver ar pressurizado no circuito, ao retirar a união esse ar comprimido será perdido.



1. Entrada de ar comprimido.
2. Conector elétrico/válvula de controle do fluxo de ar comprimido.
3. Conector elétrico/aquecimento da bomba AdBlue/DEF.
4. Entrada de AdBlue/DEF.
5. Saída/Mistura de AdBlue/DEF e ar.
6. Retorno de AdBlue/DEF.

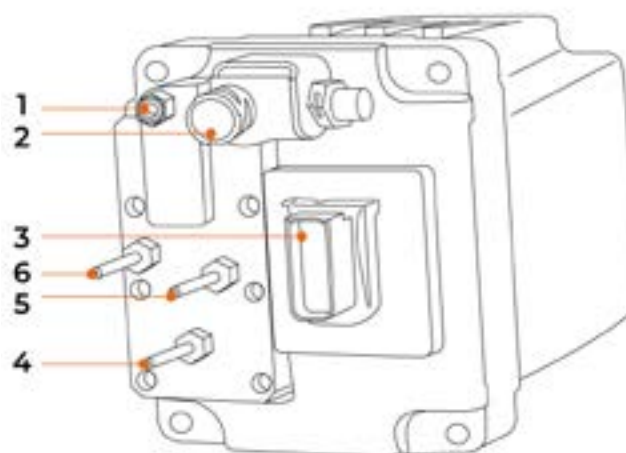

**c.** Conectar os adaptadores “4” (4a ou 4b conforme apropriado) e “5” na entrada de ar comprimido do módulo de AdBlue/DEF (1) e na saída de ar comprimido do veículo. Em seguida, conecte uma mangueira (“1” e “3”) em cada adaptador, mas ainda sem conectá-las ao tanque “2”.

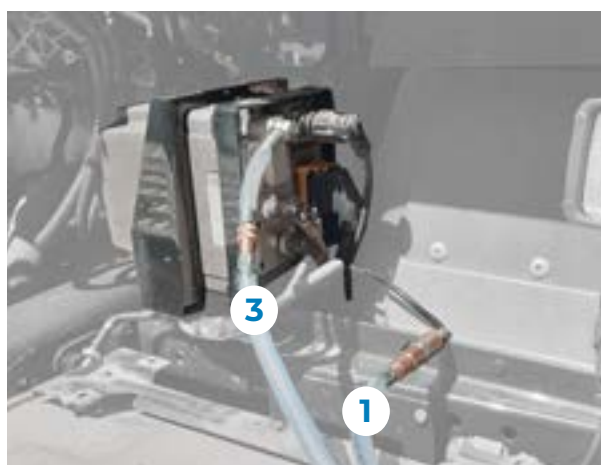

**d.** Encher o depósito “2a” or cima com 250 ml de água destilada quente (MÁX. 60 °C/140 °F), utilizando a garrafa de enchimento “6”.





e. Conectar as mangueiras “1” e “3” ao tanque “2a”.



f. Arrancar o motor e mantenha-o até carregar o circuito de ar comprimido.

g. Utilize a ferramenta de diagnóstico para realizar a ação correspondente quantas vezes forem necessárias até que se observe que pelo bico injetor apenas é expelido ar comprimido. Use um recipiente ou cilindro medidor para coletar aproximadamente 250 ml de água que será expelida pelo injetor.

### Sistema NoNOx >> Verificações de sistema “VERIFICAÇÃO DO CIRCUITO DE AR”

h. Execute a instalação pneumática novamente antes dos testes. Montar a conexão (1) para a entrada de ar comprimido no módulo de AdBlue/DEF.

**Nota:** se o circuito de ar comprimido não estiver despressurizado, ao retirar as uniões este ar comprimido será perdido.

## 2.1.3 LIMPEZA DO CIRCUITO DE ENTRADA DE AD-BLUE/DEF PARA O MÓDULO

a. Arrancar o motor e mantenha-o até que o circuito de ar comprimido seja pressurizado.

b. Desconectar as conexões (4) e (6) do módulo de AdBlue/DEF.

c. Coloque um recipiente ou tubo na boca (6) para recolher a quantidade de líquido do retorno.

d. Conectar a mangueira “7” com acoplamento rápido 3/8” à torneira de entrada de AdBlue/DEF (4). Conectar a outra extremidade ao conector rápido da parte inferior do tanque “2a”.

Previamente, o tanque deve estar vazio e sem as mangueiras do teste anterior.

e. Encher o tanque “2a” com água destilada quente (MÁX. 60 °C/140 °F) pela parte superior. Leve em consideração que a quantidade que será inserida será aproximadamente a que for dosada.



**f.** Executar a verificação de dosagem média. Usar um recipiente ou cilindro de medição para recolher a água a ser dispensada através do injetor.

**Sistema NoNOx >> Verificações do sistema >> DOSAGEM DE ADBLUE/DEF >> “DOSAGEM MÉDIA”**



## 2.1.4 PASSOS SEGUINTE

- a.** Verificar se não há erros memorizados na Unidade de Controle.
- b.** Desmontar o equipamento de limpeza do módulo de AdBlue/DEF e enxáguar todos os componentes incluindo o tanque com água quente.
- c.** Instalar as conexões do módulo de AdBlue/DEF e verificar a estanqueidade do módulo e das conexões.
- d.** Instalar as proteções de plástico do módulo de AdBlue/DEF.
- e.** Montar as placas de proteção.

## 2.2 SISTEMA ADBLUE/DEF EMITEC (MOTOR CUMMINS)

### 2.2.1 PASSOS ANTERIORES

- a. Verificar o sistema de dosagem de líquido AdBlue/DEF
- b. Remover o contato e desconectar as baterias
- c. Liberar a pressão do sistema de dosagem de AdBlue/DEF
- d. Retirar o injetor de AdBlue/DEF

**Nota:** colocar um recipiente adequado na extremidade do tubo



### 2.2.2 LIMPEZA DO CIRCUITO DE SAÍDA DE ADBLUE/DEF

- a. Desconectar o tubo de retorno de líquido AdBlue/DEF **(6)**
- b. Desconectar a linha de abastecimento de ar do módulo de dosagem de Ad-Blue/DEF **(1)**

1. Entrada de ar comprimido.
2. Conector elétrico/válvula de controle do fluxo de ar comprimido.
3. Conector elétrico/aquecimento da bomba AdBlue/DEF.
4. Entrada de AdBlue/DEF.
5. Saída/Mistura de AdBlue/DEF e ar.
6. Retorno de AdBlue/DEF.

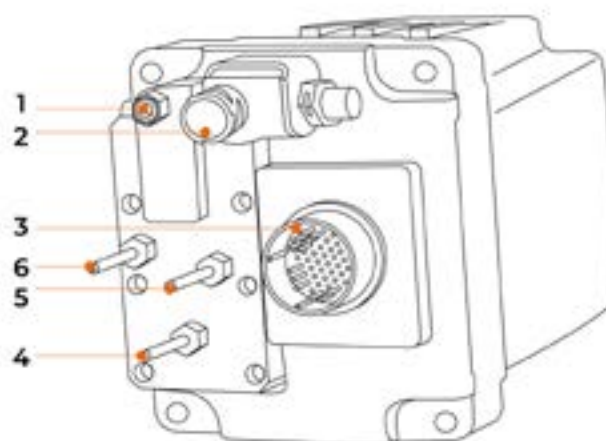



**c.** Conectar os adaptadores “4” (4a ou 4b segundo convenha) e “5” na entrada de ar comprimido do módulo de AdBlue/DEF (1) e na saída de ar comprimido do veículo. Em seguida, conectar uma mangueira (“1” e “3”) em cada adaptador, mas ainda sem conectá-las ao tanque “2a”.



**d.** Encher o depósito “2a” pela parte superior com 250 ml de água destilada quente (MÁX. 60 °C/140 °F), utilizando a garrafa de enchimento “6”.



**e.** Conectar as mangueiras “1” e “3” ao depósito/tanque “2a”

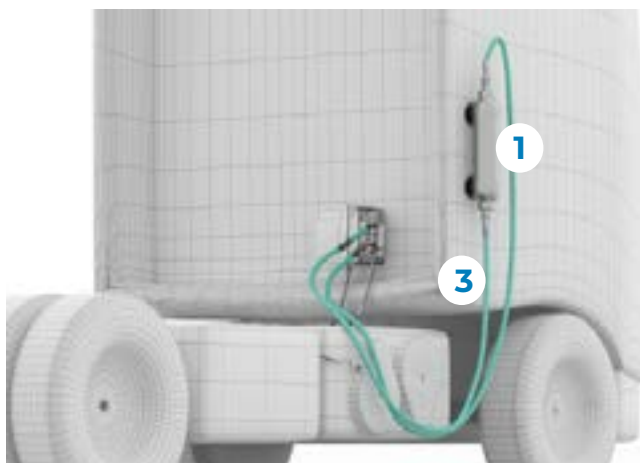



- f. Arrancar o motor
- g. Utilizar a ferramenta de diagnóstico para realizar a ação correspondente quantas vezes forem necessárias até que se observe que apenas o ar comprimido é expelido pelo bico injetor. Usar um recipiente ou cilindro medidor para coletar aproximadamente 250 ml de água que será expelida pelo injetor.

### **Atuar componentes >> “VÁLVULA SOLENÓIDE DA BOMBA DE DOSAGEM ADBLUE/DEF”**

**Nota:** neste caso, a ação indicada serve apenas para garantir a correta limpeza do circuito de AdBlue/DEF.

- h. Reconectar todos os elementos desconectados.

## 2.2.3 LIMPEZA DO CIRCUITO DE ENTRADA DE ADBLUE/DEF PARA O MÓDULO

- a. Desconectar a linha de alimentação de AdBlue/DEF do módulo de dosagem (4).
- b. Desconectar o tubo de retorno de líquido AdBlue/DEF (6).
- c. Colocar um recipiente ou tubo na boca (6) para recolher a quantidade de líquido do retorno.
- d. Conectar a mangueira “7” com acoplamento rápido 3/8 ao espigão de entrada de AdBlue/DEF (4).



- e. Conectar a mangueira ao depósito/tanque “2a”.

Previamente, o tanque deve estar vazio e sem as mangueiras do teste anterior.





**f.** Encher o tanque “2a” com 250 ml de água destilada quente (MAX. 60 °C/140 °F) pela parte superior.

**g.** Arrancar o motor.

**h.** Executar a ação correspondente com a ferramenta de diagnóstico e avaliar o resultado. Usar um recipiente ou cilindro de medição para coletar a água a ser dispensada através do injetor. Se a água não escoar completamente, repetir a ação.

### **Verificações do sistema >> “BOMBA ADBLUE/DEF”**

**Nota:** neste caso, a ação indicada serve apenas para garantir a correta limpeza do circuito de AdBlue/DEF.

**i.** Reconectar todos os elementos desconectados.

## 2.2.4 PASSOS SEGUINTE

**a.** Verificar se não há erros memorizados na Unidade de Controle.

**b.** Desmontar o equipamento de limpeza do módulo de AdBlue/DEF e enxáguar com água quente todos os componentes, inclusive o tanque.

**c.** Instalar as conexões do módulo de AdBlue/DEF e verificar a estanqueidade do módulo e das conexões.

## 2.3 SISTEMA ADBLUE/DEF ALBONAIR

### 2.3.1 PASSOS ANTERIORES

**a.** Realizar o teste de drenagem do circuito de AdBlue/DEF com a ferramenta de diagnóstico.

### **Sistema ACM >> Verificações do sistema >> “PURGA DO CIRCUITO DE ADBLUE/DEF”**

**b.** Desmontar as placas de proteção.



Para maior conforto durante o processo, desmonte também o suporte da placa lateral.



**c.** Desmontar o suporte do injetor de AdBlue/DEF e remover o injetor.



**d.** Colocar um recipiente no bico injetor.



## 2.3.2 LIMPEZA DO CIRCUITO DE ADBLUE/DEF

a. Desconectar a união de entrada AdBlue/DEF ao módulo **(3)**.

**Nota:** limpar os resíduos de AdBlue/DEF que possam cair após a desconexão.

- A.** Bomba AdBlue/DEF.
- B.** Válvula de aquecimento do tanque de AdBlue/DEF.
- C.** Sensor de Temperatura de AdBlue/DEF / Válvula de controle de ar.
- D.** Sensor de pressão de ar.
- E.** Sensor de pressão de AdBlue/DEF.

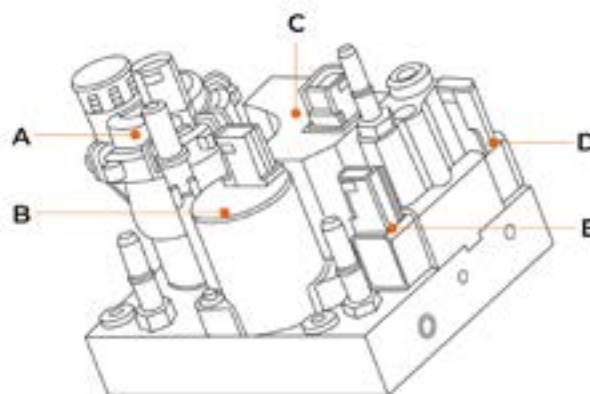

- 1.** Entrada de refrigerante.
- 2.** Entrada de ar comprimido.
- 3.** Entrada de AdBlue/DEF.

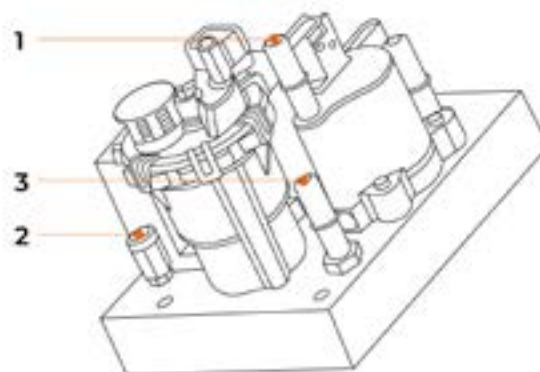

- 4.** Saída de refrigerante.
- 5.** Saída de ar.
- 6.** Saída de AdBlue/DEF.

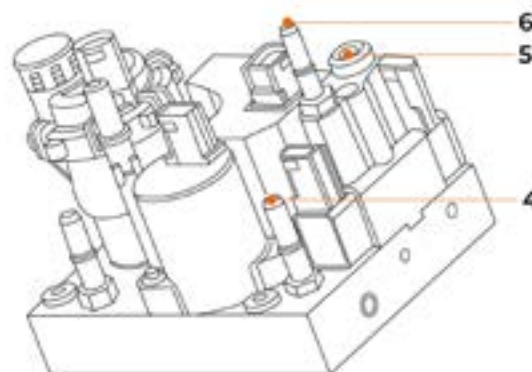



**b.** Conectar a mangueira “7” com um engate rápido de 3/8” ao espigão de entrada de AdBlue/DEF (3).



**c.** Conectar a outra extremidade da mangueira “7” ao engate rápido da parte inferior do tanque “2a”.

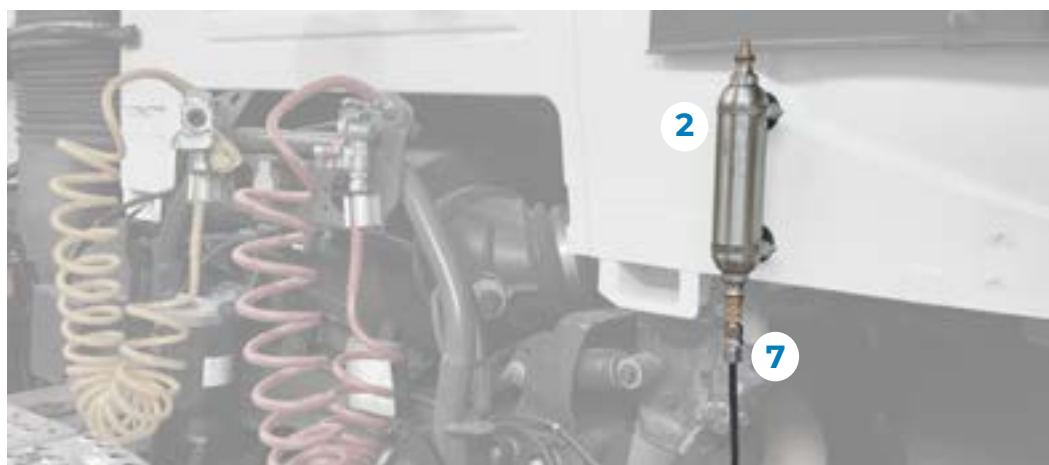

**d.** Encher o depósito “2a” pela parte superior com 200 ml de água destilada quente (MÁX. 60 °C/140 °F), utilizando a garrafa de enchimento “6”.







e. Executar a verificação de limpeza do módulo AdBlue/DEF com a ferramenta de diagnóstico.

### **Sistema ACM >> Verificações do sistema >> “LIMPEZA DO MÓDULO DE ADBLUE/DEF”**

**Nota:** para considerar que o circuito AdBlue/DEF não está obstruído e que o sistema funciona corretamente, o volume de água dosado deve estar entre os valores máximo e mínimo exibidos ao finalizar a ação.

## 2.3.3 PASSOS SEGUINTE

- a. Verificar se não há erros memorizados na Unidade de Controle.
- b. Desconectar a ferramenta de diagnóstico e retire a ignição do veículo..
- c. Desmontar o equipamento de limpeza do módulo de AdBlue/DEF e enxaguar todos os componentes incluindo o tanque com água quente.
- d. Montar a conexão do módulo de AdBlue/DEF e verificar a estanqueidade do módulo e das conexões.
- e. Montar o injetor de AdBlue/DEF.
- f. Montar as placas de proteção.

## 2.4 SISTEMA ADBLUE/DEF BOSCH DENOXTRONIC 2.2 Y DENOXTRONIC 6-HD

### 2.4.1 PASSOS ANTERIORES

- a. Realize a purga do circuito de AdBlue/DEF.

**Nota:** Desligue a ignição e aguarde 2 minutos antes de ligá-la novamente.



**b.** Localize o módulo de dosagem de AdBlue/DEF.

**Nota:** A localização depende do veículo.

**c.** Desmonte as placas de proteção, se necessário.

**d.** Desmontar o suporte do injetor de AdBlue/DEF e remover o injetor.

**Nota:** A localização depende do veículo.



**e.** Colocar um recipiente no bico do injetor.

## 2.4.2 LIMPEZA DO CIRCUITO DE SAÍDA DE ADBLUE/DEF

**a.** Desconectar os tubos de alimentação de AdBlue/DEF do módulo de dosagem **(6)**.

**Nota:** limpar os resíduos de AdBlue/DEF que possam cair após a desconexão.

**b.** Desconectar o tubo de retorno de líquido AdBlue/DEF para o depósito **(4)**.

- 1.** Saída de AdBlue/DEF.
- 2.** Saída de líquido refrigerante.
- 3.** Entrada de líquido refrigerante.
- 4.** Retorno de AdBlue/DEF.
- 5.** Conector elétrico.
- 6.** Entrada de AdBlue/DEF.

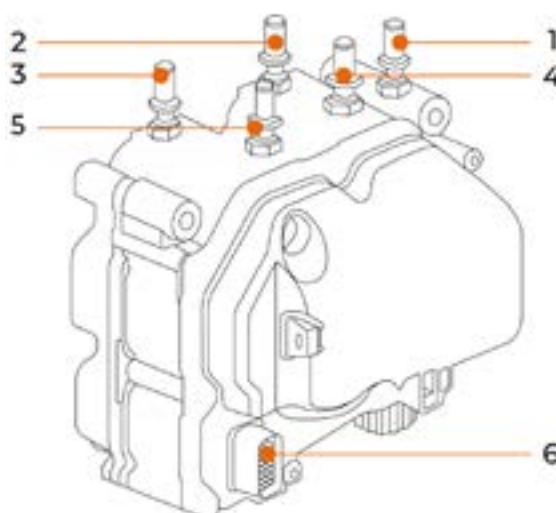

c. Conecte a mangueira “7” com engate rápido de 3/8” ao conector de entrada de AdBlue/DEF (6).

d. Conecte o adaptador “8” ao conector de retorno de AdBlue/DEF (4) e coloque um recipiente na extremidade livre.

**Nota:** durante o teste, e dependendo do veículo, o volume de água de retorno pode atingir aproximadamente 700 ml.

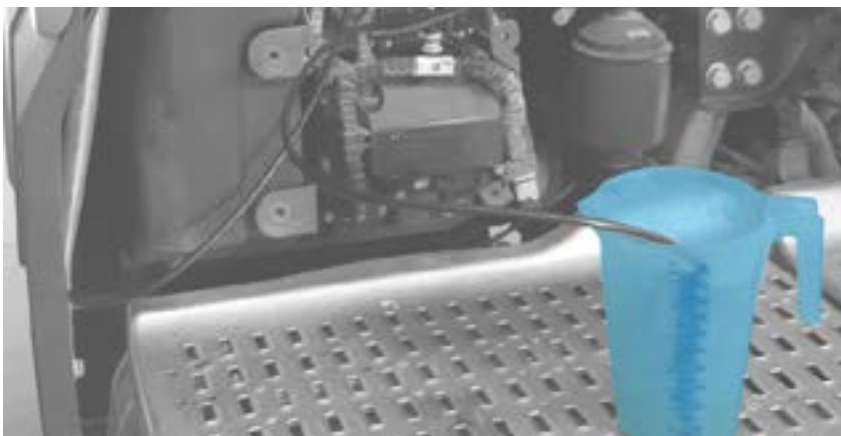

e. Conecte a outra extremidade da mangueira “7” ao conector rápido da parte inferior do depósito “2b”.

**Nota:** Coloque o depósito a uma altura superior à da entrada de AdBlue/DEF do módulo de dosagem.



f. Encha o depósito “2b” com água destilada quente (60°C/140°F MAX.) pela parte superior, usando a garrafa de enchimento “6”.



**g.** Execute a ação para a limpeza do módulo AdBlue/DEF com a ferramenta de diagnóstico.

### **Manutenção >> “LIMPEZA DO MÓDULO DE ADBLUE/DEF”**

**Observação:** para considerar que o circuito de AdBlue/DEF não está obstruído e que o sistema funciona corretamente, o volume de água dosado deve estar entre os valores máximo e mínimo exibidos ao finalizar a ação.

## 2.4.3 PASSOS SEGUINTE

**a.** Verificar se não há erros memorizados na unidade de controle.

**b.** Desconecte a mangueira “7” da parte inferior do depósito “2b”.

**c.** Desconecte a ferramenta de diagnóstico e desligue a ignição do veículo.

**Importante:** O sistema deve expulsar automaticamente a água restante dos tubos antes de continuar com o próximo passo.

**d.** Desmonte o equipamento de limpeza do módulo de AdBlue/DEF e enxágue todos os componentes, incluindo o tanque, com água quente.

**e.** Monte todos os componentes desmontados nos passos anteriores.

# ●.cojali

Jaltest.com  
cojali.com

2023 V.1 PT



Local Distributor



**AdBlue/DEF-module  
reinigingskit**

Handleiding

[jaltest.com](http://jaltest.com)



Rev. 01



## AdBlue/DEF-module reinigingskit

Handleiding



# Index

Index	3
<b>Algemene informatie</b>	<b>4</b>
1.1 PRODUCT OMSCHRIJVING	4
1.2 INHOUD	4
1.3 TOEPASSING	4
1.4 VEILIGHEIDSMATREGELEN	5
<b>Procedure</b>	<b>6</b>
2.1 ADBLUE/DEF EMITEC SYSTEEM (NONOX)	6
2.1.1 VOORGAANDE STAPPEN	6
2.1.2 REINIGEN VAN HET ADBLUE/DEF UITGANGSCIRCUIT	7
2.1.3 REINIGEN VAN HET ADBLUE/DEF AANZUIGCIRCUIT	9
2.1.4 VOLGENDE STAPPEN	10
2.2 ADBLUE/DEF EMITEC SYSTEEM (CUMMINS MOTOR)	11
2.2.1 VOORGAANDE STAPPEN	11
2.2.2 REINIGEN VAN HET ADBLUE/DEF UITGANGSCIRCUIT	11
2.2.3 REINIGEN VAN HET ADBLUE/DEF AANZUIGCIRCUIT	13
2.2.4 VOLGENDE STAPPEN	14
2.3 ALBONAIR ADBLUE/DEF SYSTEEM	14
2.3.1 VORIGE STAPPEN	14
2.3.2 REINIGEN VAN HET ADBLUE/DEF CIRCUIT	16
2.3.3 VERVOLGSTAPPEN	18
2.4 BOSCH DENOXTRONIC 2.2 EN DENOXTRONIC 6-HD ADBLUE/DEF-SYSTEEM	18
2.4.1 VOORGAANDE STAPPEN	18
2.4.2 ADBLUE/DEF-CIRCUIT REINIGING	19
2.4.3 VOLGENDE STAPPEN	21

## Makkelijke navigatie

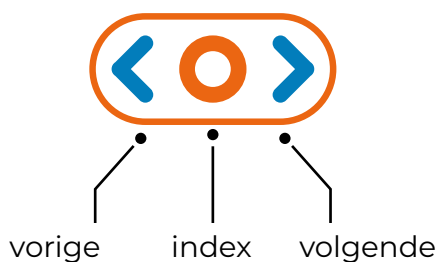

Snellere toegang tot alle inhoud die u nodig hebt door te klikken op



# 1 Algemene informatie

## 1.1 PRODUCT OMSCHRIJVING

Apparatuur voor het reinigen van de gekristalliseerde AdBlue/DEF-resten in de doozermodule, de injectorleidinging en de injector.

## 1.2 INHOUD

**1.3.** Leidingen.

**2.** Tank 0.4l.

**3.** Tank 1.5l.

**4.** Adapter om de ingaande luchtleiding te verbinden met de AdBlue./DEF-module. (4a en 4b).

**5.** Adapter om de persluchttoevoer van het voertuig aan te sluiten op de AdBlue/DEF-module.

**6.** Vulfles.

**7.** Adapter voor de AdBlue/DEF aanzuig van de module.

**8.** Adapter voor AdBlue/DEF-retour naar de module.

**9.** 3/8" adapters voor de aansluiting van de aanvoer- en retourleidingen op de AdBlue/DEF-tank.

**10.** 5/16" adapters voor de aansluiting van de inlaat- en retourleidingen op de AdBlue/DEF-tank.

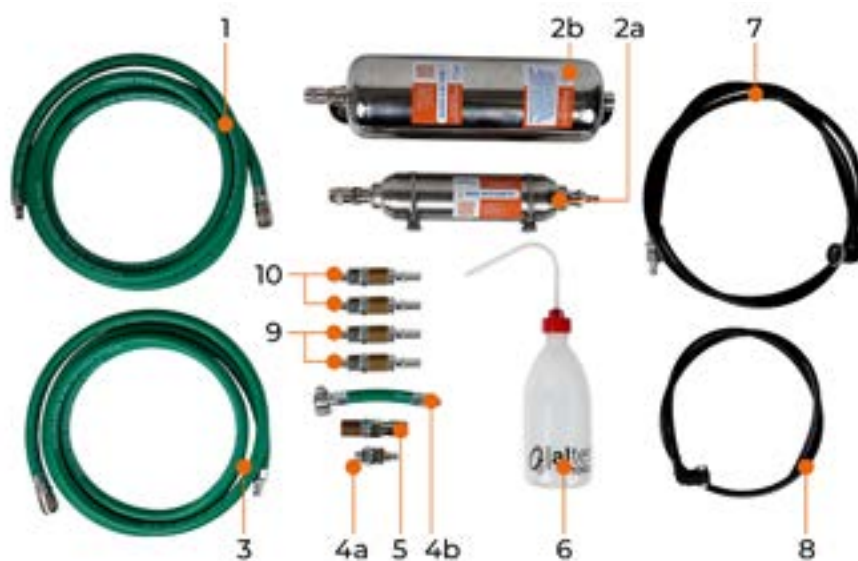

## 1.3 TOEPASSING

- NoNOX systeem (MAN TGL, TGM, TGS, TGM en Euro 6 bussen met AdBlue Emitec systeem).
- AdBlue/DEF Emitec-systeem in voertuigen met Cummins-motor.
- Albonair AdBlue/DEF systeem (VOLVO, RENAULT UD vrachtwagens en andere Euro 6 voertuigen).
- Bosch Denoxtronic 2.2 en Denoxtronic 6-HD AdBlue/DEF-systeem (DAF, IVECO, MAN, andere Euro 6-voertuigen, landbouwmachines, OHW, enz.).

## 1.4 VEILIGHEIDSMATREGELEN

Se deben tener en cuenta las siguientes precauciones de seguridad para evitar accidentes y/o lesiones:

- Colocar el vehículo en una superficie plana.
- Aplicar el freno de estacionamiento.
- Posicionar la palanca de cambio de marcha en punto muerto o neutro.
- Evitar el contacto con piezas que puedan permanecer a altas temperaturas o en movimiento.
- Utilizar una indumentaria adecuada.

## 2 Procedure

### 2.1 ADBLUE/DEF EMITEC SYSTEEM (NONOX)

#### 2.1.1 VOORGAANDE STAPPEN

a. Voer de aftaptest van het AdBlue/DEF-circuit uit met het diagnoseapparaat.

**NoNOx systeem >> Systeemcontroles “SYSTEEM VULLEN EN ONTLUCHTEN”**

b. Demonteer de bovenste, voor- en zijbeschermingsplaten.



c. Demonteer de plaatsteunen.



**d.** Demonteer de AdBlue/DEF-verstuiverbevestiging en verwijder de verstuiver.

- Demonteer de klem.
- Draai de bevestigingsmoer los.
- Verwijder de AdBlue/DEF-verstuiver en schroef deze weer in de bevestigingsmoer.
- Reinig de adblue-verstuiver.



**Opmerking:** demonteer voor uw comfort tijdens de volgende stappen de NOx-sensorbevestigingen.

**e.** Demonteer de bescherming van de AdBlue/DEF-module.



## 2.1.2 REINIGEN VAN HET ADBLUE/DEF UITGANGSCIRCUIT

**a.** Evacueer de pneumatische toevoerdruk voor meer comfort bij het loskoppelen of verwijderen van leidingen waardoor perslucht stroomt.

**b.** Demonteer de persluchtaanzuigaansluiting op de AdBlue/DEF-module **(1)**.

**Opmerking:** als het voertuig perslucht in het circuit heeft, gaat deze perslucht verloren bij het verwijderen van de aansluiting.



1. Persluchttoevoer..
2. Elektrische aansluiting / Regelklep persluchtdebiet.
3. Elektrische connector / AdBlue/ DEF-pompverwarming.
4. AdBlue/DEF-aanzuig.
5. AdBlue/DEF en lucht mengeling.
6. AdBlue/DEF-retour.

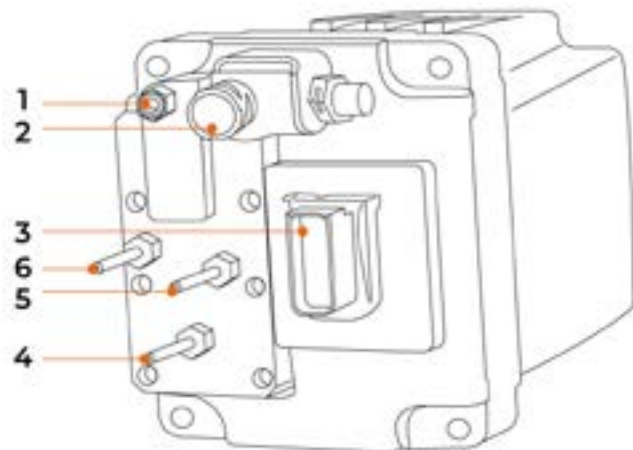

c. Sluit de adapters “4” (4a of 4b naargelang het geval) en “5” aan op de persluchttoevoer van de AdBlue/DEF-module (1) en op de persluchtuitgang van het voertuig. Verbind vervolgens een slang (“1” en “3”) op elke adapter, maar sluit ze nog niet aan op de tank “2a”.

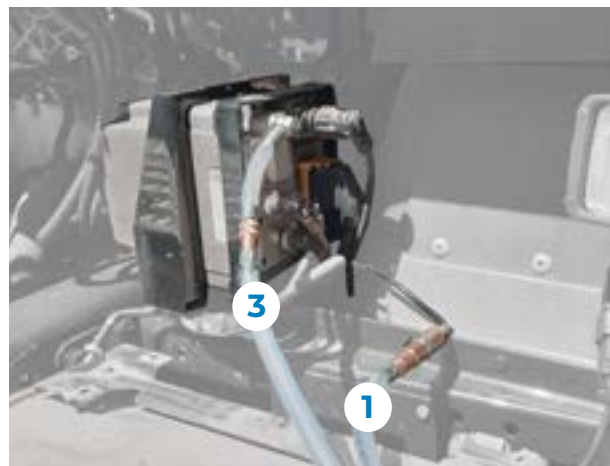

d. Vul tank “2a” met 250 ml heet gedestilleerd water (MAX. 60°C/140°F) vanaf het bovenste gedeelte, met behulp van de vulfles “6”.



e. Sluit de slangen “1” en “3” aan op tank “2a”.



f. Start de motor en laat deze draaien totdat het persluchtcircuit vol is.

g. Voer de overeenkomstige handeling zo vaak als nodig uit met behulp van het diagnoseapparaat totdat alleen perslucht door het verstuivermondstuk wordt uitgestoten. Gebruik een bak of maatcilinder om ongeveer 250 ml water op te vangen dat door de injector wordt uitgestoten.

#### **NoNOx systeem >> Systeemcontroles “LUCHTCIRCUIT CONTROLE”**

h. Verbind de pneumatische installatie uit voorafgaand aan de test. Monteer de aansluiting (1) van de persluchttoevoer op de AdBlue/DEF-module.

**Opmerking:** als het persluchtcircuit niet drukloos wordt gemaakt, gaat bij het verwijderen van de aansluitingen deze perslucht verloren.

### 2.1.3 REINIGEN VAN HET ADBLUE/DEF AANZUIGCIRCUIT

a. Start de motor en laat deze draaien totdat het persluchtcircuit vol is.

b. Koppel de aansluitingen (4) en (6) los van de AdBlue/DEF-module.

c. Plaats een container of buis op de verstuiver (6) om de hoeveelheid retourvloeistof op te vangen.

d. Sluit de slang “7” met snelkoppeling van 3/8” aan op de AdBlue/DEF aanzuigaansluiting (4). Sluit het andere uiteinde aan op de snelkoppeling aan de onderkant van de tank “2a”.

Alvorens verder te gaan dient de tank leeg te zijn en zonder de slangen van de vorige test.

e. Vul tank “2a” met gedestilleerd water (MAX. 60°C/140°F) vanaf het bovenste gedeelte. Houd er rekening mee dat de ingevoerde hoeveelheid ongeveer de gedoseerde hoeveelheid zal zijn.

**f.** Voer de gemiddelde doseringscontrole uit. Gebruik een bak of maatcilinder om het te doseren water via de injector op te vangen.

### **NoNOx systeem >> Systeemcontroles >> ADBLUE/DEF DOSERING >> “MEDIUM DOSERING”**



## 2.1.4 VOLGENDE STAPPEN

- a.** Controleer of er geen fouten zijn opgeslagen in de regeleenheid.
- b.** Demonteer de reinigingskit van de AdBlue/DEF-module en spoel alle componenten inclusief de tank af met warm water.
- c.** Sluit de AdBlue/DEF module aansluitingen aan en controleer de dichtheid van zowel de module als de aansluitingen.
- d.** Monteer de kunststof bescherming van de AdBlue/DEF-module.
- e.** Monteer de beschermplaten.

## 2.2 ADBLUE/DEF EMITEC SYSTEEM (CUMMINS MOTOR)

### 2.2.1 VOORGAANDE STAPPEN

- a. Controleer het AdBlue/DEF doseersysteem
- b. Zet het contact uit en koppel de batterijen af
- c. Laat de druk van het AdBlue/DEF doseersysteem af
- d. Verwijder de AdBlue/DEF injector

**Opmerking:** plaats een gepaste opvangbeker aan het einde van de leiding



### 2.2.2 REINIGEN VAN HET ADBLUE/DEF UITGANGSCIRCUIT

- a. Verwijder de AdBlue/DEF retourleiding (6)
- b. Verwijder de luchttoevoerleiding van de AdBlue/DEF doseermodule (1)

1. Persluchttoevoer..
2. Elektrische aansluiting / Regelklep persluchtdebiet.
3. Elektrische connector / AdBlue/DEF-pompverwarming.
4. AdBlue/DEF-aanzuig.
5. AdBlue/DEF en lucht mengeling.
6. AdBlue/DEF-retoour.

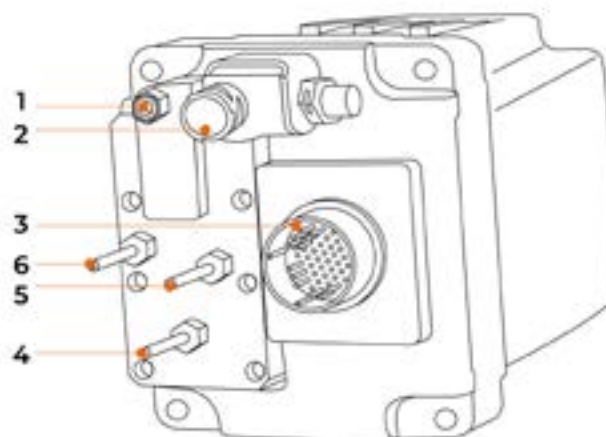





c. Verbind adapters “4” (4a of 4b als nodig) en “5” met de ingang van de perslucht van de AdBlue/DEF module (1) en de persluchttoevoer. Vervolgens, sluit de leidingen aan (“1” en “3”) op de adapters zonder deze reeds op de tank aan te sluiten “2a”.



d. Vul tank “2a” met 250ml gedestilleerd water (MAX. 60°C/140°F) van bovenaf met de vulfles “6”.



e. Verbind leiding “1” en “3” met de tank “2a”

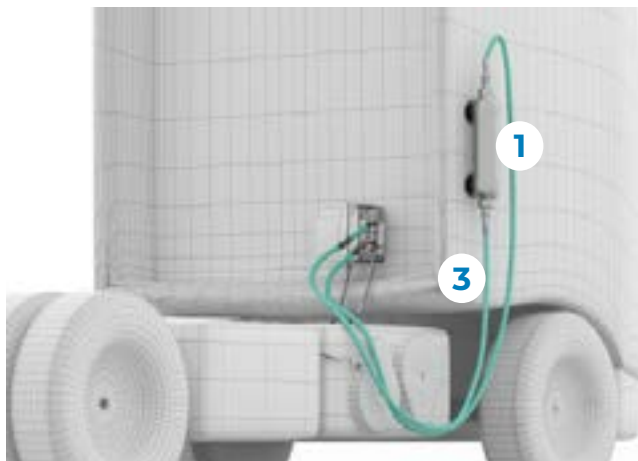



- f. Start de motor
- g. Voer de bijbehorende actie zo vaak als nodig uit met behulp van het diagnosehulpmiddel totdat alleen perslucht door het injectormondstuk wordt verdreven. Gebruik een opvangbeker of meetcilinder om ongeveer 250 ml water op te vangen dat door de injector wordt gespoten.

### Aansturing componenten >> “MAGNEETVENTIEL VAN DE ADBLUE/DEF-DOSEERPOMP”

**Opmerking:** in dit geval dient de aangegeven actie alleen de correcte reiniging van het AdBlue/DEF-circuit te garanderen.

- h. Sluit alle elementen die eerder waren losgekoppeld opnieuw aan.

## 2.2.3 REINIGEN VAN HET ADBLUE/DEF AANZUIGCIRCUIT

- a. Koppel de AdBlue/DEF-toevoerleiding los van de doseermodule (4).
- b. Koppel de AdBlue/DEF-retourleiding los (6).
- c. Plaats een opvangbak of maatbeker aan de injector (6) om de hoeveelheid retourvloeistof op te vangen.
- d. Sluit slang “7” met snelkoppeling van 3/8” aan op de AdBlue/DEF-inlaatconnector (4).



- e. Sluit de slang aan op tank “2a”.

Voorafgaand moet de tank leeg zijn en zonder de slangen van de vorige test.





**f.** Vul tank “2a” met 250 ml heet gedestilleerd water (MAX. 60 °C / 140 °F) van bovenaf.

**g.** Start de motor

**h.** Voer de bijbehorende actie uit met het diagnosetoestel en beoordeel het resultaat. Gebruik een opvangbak of maatbeker om het water op te vangen dat door de injector wordt gedoseerd. Als het water niet volledig is afgevoerd, herhaalt u de actie.

### **System controle >> “ADBLUE/DEF POMP”**

**Opmerking:** in dit geval dient de aangegeven actie alleen om de juiste reiniging van het AdBlue/DEF-circuit te garanderen.

**i.** Verbind opnieuw alle elementen die eerder zijn losgekoppeld.

## 2.2.4 VOLGENDE STAPPEN

**a.** Controleer of er geen fouten zijn opgeslagen in de regeleenheid.

**b.** Demonteer de reinigingskit van de AdBlue/DEF-module en spoel alle componenten met heet water, inclusief de tank.

**c.** Sluit de AdBlue/DEF-module aansluitingen aan en controleer de afdichting van zowel de module als de aansluitingen.

## 2.3 ALBONAIR ADBLUE/DEF SYSTEEM

### 2.3.1 VORIGE STAPPEN

**a.** Voer de AdBlue/DEF-circuit opvoertest uit met het diagnosetoestel.

### **ACM-systeem >> Systemcontroles >> “ADBLUE/DEF CIRCUIT ONTLUCHTING”**

**b.** Demonteer de beschermplaten.



Voor meer comfort tijdens het proces, demonteer ook de steun van de zijplaat.



**c.** Demonteer de AdBlue/DEF-injectorbevestiging en verwijder de injector.



**d.** Plaats een opvangbak onder de injector.



## 2.3.2 REINIGEN VAN HET ADBLUE/DEF CIRCUIT

a. Demonteer de AdBlue/DEF-aanzuigaansluiting op de module **(3)**.

**Opmerking:** Reinig de resterende AdBlue/DEF die mogelijk na het demonteren valt.

- A.** AdBlue/DEF pump.
- B.** Verwarmingsklep van de AdBlue/DEF-tank.
- C.** AdBlue/DEF temperatuursensor / Luchtregelventiel.
- D.** Luchtdruksensor.
- E.** AdBlue/DEF-druksensor.

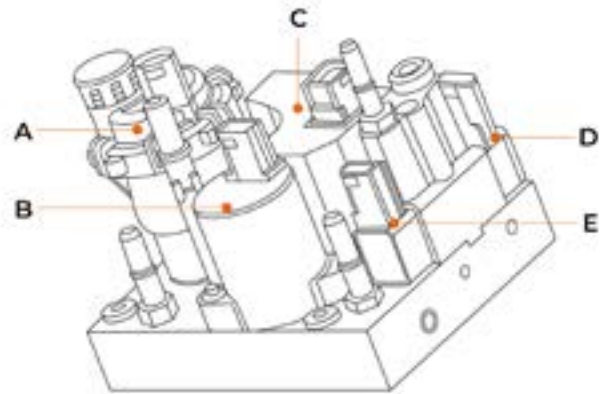

- 1.** Ingang koelvloeistof.
- 2.** Toevoer perslucht.
- 3.** AdBlue/DEF toevoer.

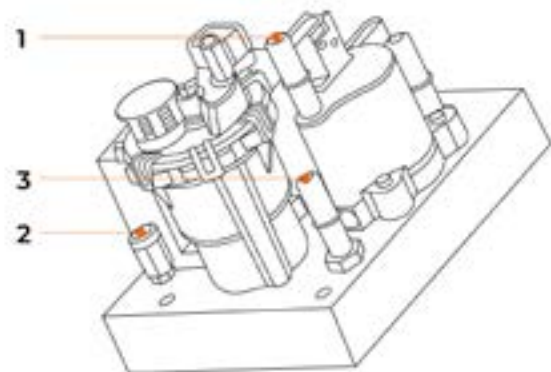

- 4.** Uitgang koelvloeistof.
- 5.** Uitgang perslucht.
- 6.** AdBlue/DEF uitgang.

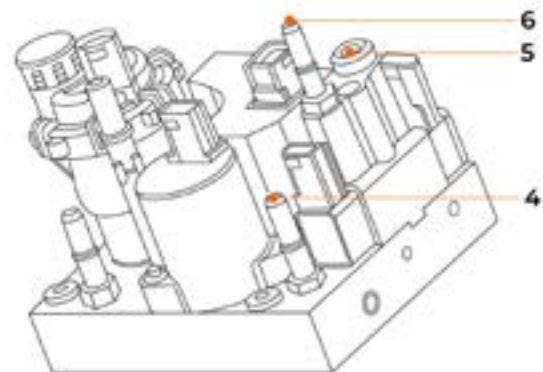



**b.** Sluit slang “7” met snelkoppeling van 3/8” aan op de AdBlue/DEF-inlaatconnector (3).



**c.** Sluit het andere uiteinde van slang “7” aan op de snelkoppeling aan de onderkant van tank “2a”.



**d.** Vul tank “2a” met ongeveer 200 ml heet gedestilleerd water (MAX. 60 °C / 140 ° F) van het bovenste deel, met behulp van vulfles “6”.





- e. Voer de reinigingscontrole van de AdBlue/DEF-module uit met het diagnosetoestel.

### ACM systeem >> Systeem controle >> "ADBLUE/DEF MODULE REINIGEN"

**Opmerking:** Om ervoor te zorgen dat het AdBlue/DEF-circuit niet verstopt is en het systeem correct werkt, moet het gedoseerde watervolume tussen de maximum- en minimumwaarden liggen die aan het einde van de actie worden weergegeven.

## 2.3.3 VERVOLGSTAPPEN

- a. Controleer of er geen fouten zijn opgetreden in de besturingseenheid.
- b. Koppel het diagnosetoestel los en schakel het contact van het voertuig uit.
- c. Demonteer de AdBlue/DEF-module reinigingskit en spoel alle componenten, inclusief de tank, af met heet water.
- d. Monteer de AdBlue/DEF-moduleaansluiting en controleer de afdichting van zowel de module als de aansluitingen.
- e. Monteer de AdBlue/DEF-injector.
- f. Monteer de beschermplaten.

## 2.4 BOSCH DENOXTRONIC 2.2 EN DENOXTRONIC 6-HD ADBLUE/DEF-SYSTEEM

### 2.4.1 VOORGAANDE STAPPEN

- a. Voer de ontluchting van het AdBlue/DEF-circuit uit.

**Opmerking:** Zet het contact uit en wacht 2 minuten voordat u het weer inschakelt.



**b.** Localiseer de AdBlue/DEF-doseringsmodule.

**Opmerking:** De locatie hangt af van het voertuigtype.

**c.** Demonteer de beschermplaten indien nodig.

**d.** Demonteer de AdBlue/DEF-injectorbevestiging en verwijder de injector.

**Opmerking:** De locatie hangt af van het voertuigtype.



**e.** Plaats een opvangbak onder de injector.

## 2.4.2 ADBLUE/DEF-CIRCUIT REINIGING

**a.** Koppel de AdBlue/DEF-toevoerleiding los van de doseermodule **(6)**.

**Opmerking:** Reinig de resterende AdBlue/DEF die mogelijk na het demonteren valt.

**b.** Koppel de AdBlue/DEF-vloeistofretourleiding naar de tank los **(4)**.

- 1.** AdBlue/DEF uitgang.
- 2.** Uitgang koelvloeistof.
- 3.** Ingang koelvloeistof.
- 4.** AdBlue/DEF retour.
- 5.** Elektrische aansluiting.
- 6.** AdBlue/DEF toevoer.

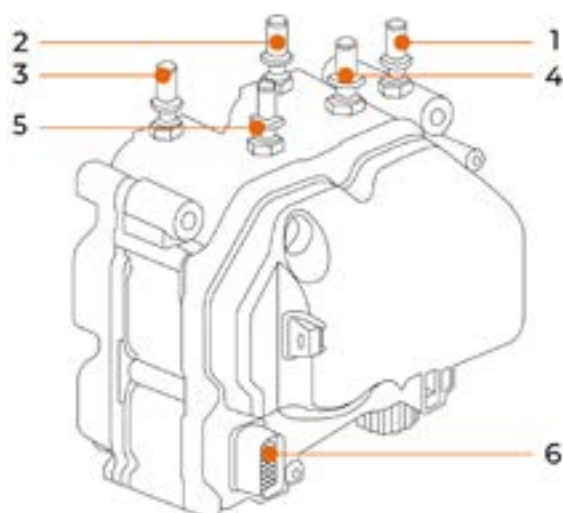



c. Sluit slang “7” met snelkoppeling van 3/8” aan op de AdBlue/DEF-inlaatconnector (6).

d. Sluit adapter “8” aan op de AdBlue/DEF-retouransluiting (4) en plaats een opvangbak aan het vrije uiteinde.

**Opmerking:** tijdens de test kan de hoeveelheid opvangwater, afhankelijk van het voertuig, ongeveer 700 ml bedragen.



e. Sluit het andere uiteinde van slang “7” aan op de snelkoppeling aan de onderkant van tank “2b”.

**Let op:** Plaats de tank op een hoogte boven de aanzuigaansluiting van de AdBlue/DEF-doseermodule.



f. Vul tank “2b” met heet gedestilleerd water (60°C/140°F MAX.) vanaf het bovenste gedeelte, met behulp van de vulfles “6”.



- g.** Voer de reinigingscontrole van de AdBlue/DEF-module uit met het diagnosetoestel.

### Onderhoud >> “ADBLUE/DEF-MODULE REINIGEN”

**Opmerking:** Om ervoor te zorgen dat het AdBlue/DEF-circuit niet verstopt is en het systeem correct werkt, moet het gedoseerde watervolume tussen de maximum- en minimumwaarden liggen die aan het einde van de actie worden weergegeven.

## 2.4.3 VOLGENDE STAPPEN

- a.** Controleer of er geen fouten zijn opgeslagen in de besturingseenheid.
- b.** Koppel slang “7” los van de bodem van tank “2b”.
- c.** Koppel het diagnosetoestel los en schakel het contact van het voertuig uit.

**Belangrijk:** Het systeem moet automatisch het resterende water uit de leidingen lozen voordat verder wordt gegaan met de volgende stap.

- d.** Demonteer de AdBlue/DEF-module reinigingskit en spoel alle componenten af, inclusief de tank, met heet water.
- e.** Monteer alle componenten die in de vorige stappen zijn gedemonteerd.

# ●.cojali

Jaltest.com  
cojali.com

2023 V.1 NL



Local Distributor



**Sada na čištění modulu  
AdBlue/DEF**

Uživatelský manuál

[jaltest.com](http://jaltest.com)



Rev. 01



## Sada na čištění modulu AdBlue/DEF

Uživatelský manuál



# Index

Index	3
Základní informace	4
1.1 POPIS PRODUKTU	4
1.2 OBSAH	4
1.3 POUŽITÍ	4
Procedura	5
2.1 ADBLUE/DEF EMITEC SYSTEM (NONOX)	5
2.1.1 ÚVODNÍ KROKY	5
2.1.2 ČIŠTĚNÍ VÝSTUPNÍHO OKRUHU ADBLUE/DEF	6
2.1.3 ČIŠTĚNÍ OKRUHU ADBLUE/DEF NA VSTUPU DO MODULU	8
2.1.4 NÁSLEDUJÍCÍ KROKY	9
2.2 ADBLUE/DEF EMITEC SYSTEM (CUMMINS MOTOR)	10
2.2.1 ÚVODNÍ KROKY	10
2.2.2 ČIŠTĚNÍ VÝSTUPNÍHO OKRUHU ADBLUE/DEF	10
2.2.3 ČIŠTĚNÍ OKRUHU ADBLUE/DEF NA VSTUPU DO MODULU	12
2.2.4 NÁSLEDUJÍCÍ KROKY	13
2.3 ALBONAIR ADBLUE/DEF SYSTÉM	13
2.3.1 PŘEDCHÁDZAJÚCE KROKY	13
2.3.2 ČIŠTENIE OKRUHU ADBLUE/DEF	15
2.3.3 NASLEDUJÚCE KROKY	17

## Jednoduchá navigace

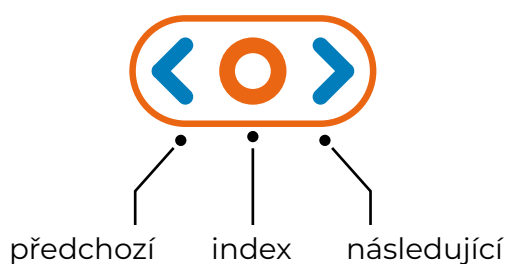

Rychlý přístup  
do kterékoliv  
části kliknutím

# 1 Základní informace

## 1.1 POPIS PRODUKTU

Zařízení pro čištění od krystalických zbytků AdBlue/DEF v dávkovacím modulu, ve vstříkovacím potrubí, nebo vstříkovači.

## 1.2 OBSAH

**1.3.** Hadice.

**2a.** Nádrž 0,4l.

**2b.** Nádrž 1,5l.

**4.** Adaptér na připojení stlačeného vzduchu na vstup do dávkovacího modulu (4a a 4b).

**5.** Adaptér na připojení stlačeného vzduchu z vozidla do dávkovacího modulu.

**6.** Plnicí nádržka

**7.** Adaptér na vstup do modulu AdBlue/DEF

**8.** Adaptér pre návrat kvapaliny AdBlue/DEF do modulu.

**9.** 3/8" adaptéry na pripojenie prívodného a vratného potrubia k nádrži AdBlue/DEF.

**10.** Adaptéry 5/16" na pripojenie prívodného a vratného potrubia k nádrži AdBlue/DEF.

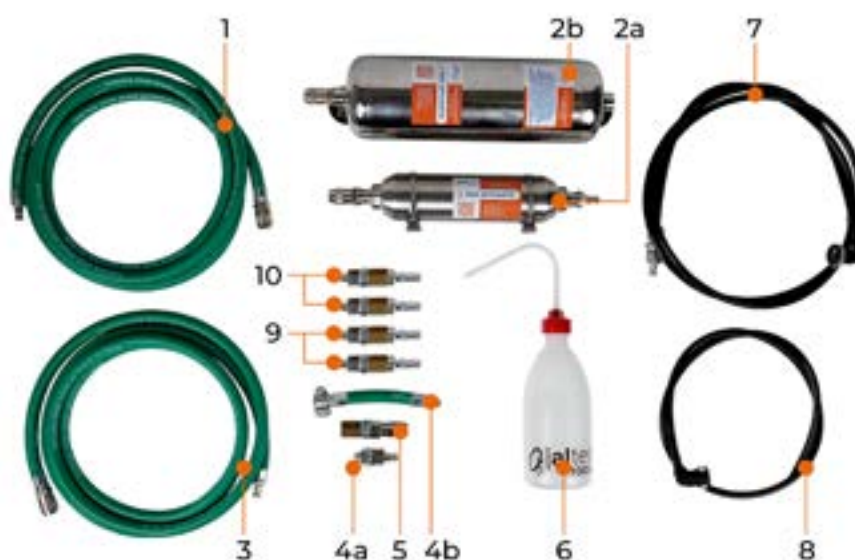

## 1.3 POUŽITÍ

-NoNOX system (MAN TGL, TGM, TGS, TGX and Euro 6 buses with AdBlue/DEF Emitec system).

-AdBlue/DEF Emitec systém vo vozidlách s motorom Cummins.

-AdBlue/DEF Albonair systém (nákladné vozidlá VOLVO, RENAULT UD a iné vozidlá Euro 6).

-AdBlue/DEF systém Bosch Denoxtronic 2.2 a Denoxtronic 6-HD (DAF, IVECO, MAN, iné vozidlá Euro 6, poľnohospodárska a OHW mechanizácia, atď!).

## 1.4 BEZPEČNOSTNÉ OPATRENIA

Z dôvodu predídenia nehodám a/alebo zraneniam, je potrebné dodržiavať nasledujúce bezpečnostné opatrenia:

- Postavte vozidlo na rovný povrch.
- Aktivujte parkovaciu brzdu.
- Radenie v polohe neutrál.
- Vyhnite sa kontaktu s časťami, ktoré by mohli zostať príliš horúce alebo tých ktoré sa môžu pohybovať.
- Používajte vhodný pracovný odev.



## 2 Procedura

### 2.1 ADBLUE/DEF EMITEC SYSTEM (NONOX)

#### 2.1.1 ÚVODNÍ KROKY

**a.** Provedte proces čištění AdBlue/DEF pomocí diagnostického nástroje.

#### **NoNOx systém - Prověření systému - Plnění a odvzdušnění systému**

**b.** Odmontujte horní, přední a boční ochranné kryty.



**c.** Odmontujte držáky krytů.



**d.** Odmontujte upevnění vstřikovače AdBlue/DEF a vytáhněte vstřikovač

- Odmontujte sponu.
- Odšroubujte upevňovací matici.
- Odsuňte vsřikovač AdBlue/DEF a našroubujte znovu upevňovací matici.
- Vyčistěte trysku vstřikovače.



**Note:** pro zjednodušení během dalších kroků, odmontujte upevnění Nox senzoru.

**e.** Odmontujte ochrany modulu AdBlue/DEF.



## 2.1.2 ČIŠTĚNÍ VÝSTUPNÍHO OKRUHU ADBLUE/DEF

**a.** Odvzdušněte přívodní pneumatický tlak pro lepší pohodlí při odpojování nebo odstraňování potrubí, kterými proudí stlačený vzduch.

**b.** Odpojte vstup stlačeného vzduchu na modulu AdBlue/DEF (1).

**Poznámka:** pokud má vozidlo v okruhu stlačený vzduch, při odpojení tohoto připojení se tento stlačený vzduch ztratí.



1. Vstup stlačeného vzduchu.
2. Elektrický konektor / Elektroventil regulace stlačeného vzduchu.
3. Elektrický konektor / Vyhřívání čerpadla AdBlue/DEF.
4. Vstup kapaliny AdBlue/DEF.
5. Výstup aerosolu kapalina/vzduch
6. Odtok zpětného potrubí do nádrže.

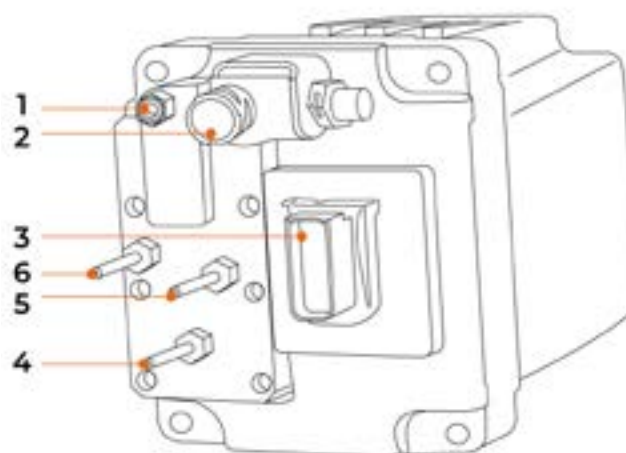

**c.** Připojte adaptér “4” (podle potřeby 4a nebo 4b) a “5” do sání stlačeného vzduchu modulu AdBlue/DEF (1) a do výfuku stlačeného vzduchu vozidla. Dále připojte hadici (“1” a “3”) v každém adaptéru, ale zatím bez připojení k nádrži “2”.

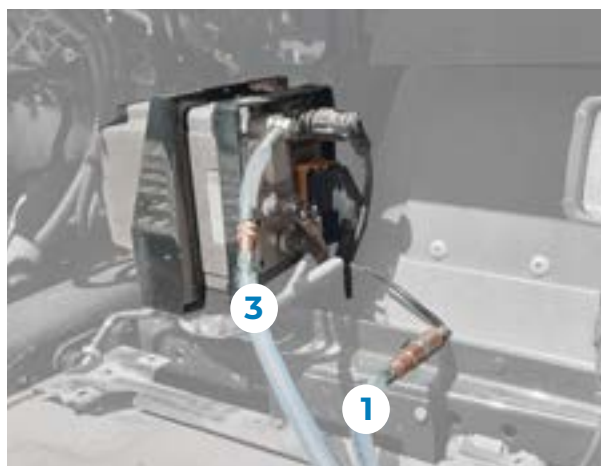

**d.** Naplňte nádrž “2a” množstvím 250 ml horké destilované vody (60 °C/140°F) z horní části pomocí plnicí lahve “6”.



e. Připojte hadice “1” a “3” na zásobník “2a”.



f. Nastartujte motor, a udržujte jej na volnoběhu, dokud se obvody stlačeného vzduchu znovu natlakují.

g. Proveďte příslušnou akci tolikrát, kolikrát je to nutné, pomocí diagnostického nástroje, dokud nebude tryskou vstřikovače vytlačen pouze stlačený vzduch. Pomocí nádoby nebo odměrného válce odeberte přibližně 250 ml vody, která bude vytlačena vstřikovačem.

### NoNOx systém - Proveření systému - Kontrola vzduchového okruhu

h. Před zkouškami proveďte znovu pneumatickou instalaci. Namontujte připojení (1) přívodu stlačeného vzduchu k modulu AdBlue/DEF.

**Poznámka:** pokud není okruh stlačeného vzduchu odtlakován, po demontování spojů se tento stlačený vzduch ztratí.

## 2.1.3 ČIŠTĚNÍ OKRUHU ADBLUE/DEF NA VSTUPU DO MODULU

a. Nastartujte motor, a udržujte jej na volnoběhu, dokud se obvody stlačeného vzduchu znovu natlakují.

b. Odpojte připojení (4) a (6) z modulu AdBlue/DEF.

c. Umístěte pod trysku (6) nádobu nebo hadici, abyste zachytili množství vratné kapaliny.

d. Připojte hadici “7” pomocí rychlospojky 3/8 ke vstupnímu konektoru AdBlue/DEF (4). Druhý konec připojte k rychlému konektoru ve spodní části nádrže “2a”.

Nejdříve, musela být samozřejmě nádrž prázdná a bez hadic předchozí zkoušky.

e. Naplňte nádrž “2a” destilovanou vodou z horní části (60 °C/140°F). Počítejte s tím, že naplněné množství bude přibližně to, které se dávkuje.

**f.** Proveďte test průměrného dávkování. Pomocí nádoby nebo odměrného válce sbírejte vodu, která má být dávkována, ze vstřikovače.

### **NoNOx systém - Přověření systému - AdBlue/DEF dávkování - střední dávkování**



## 2.1.4 NÁSLEDUJÍCÍ KROKY

- a.** Zkontrolujte, zda nejsou v řídicí jednotce uloženy žádné chyby.
- b.** Demontujte čisticí zařízení modulu AdBlue/DEF a opláchněte všechny součásti včetně nádrže horkou vodou.
- c.** Zapojte přípojky modulu AdBlue/DEF a zkontrolujte těsnost modulu i připojení.
- d.** Namontujte plastové ochrany modulu AdBlue/DEF.
- e.** Namontujte ochranné kryty.

## 2.2 ADBLUE/DEF EMITEC SYSTEM (CUMMINS MOTOR)

### 2.2.1 ÚVODNÍ KROKY

- a. Zkontrolujte systém dávkování kapaliny AdBlue/DEF
- b. Vypněte zapalování a odpojte baterie vozidla
- c. Uvolněte tlak z dávkovacího systému AdBlue/DEF
- d. Vyjměte vstříkovací trysku AdBlue/DEF

**Poznámka:** na konec trubky umístěte vhodnou nádobu



### 2.2.2 ČIŠTĚNÍ VÝSTUPNÍHO OKRUHU ADBLUE/DEF

- a. Odpojte zpětné potrubí kapaliny AdBlue/DEF **(6)**
- b. Odpojte přívod vzduchu od dávkovacího modulu AdBlue/DEF **(1)**

1. Vstup stlačeného vzduchu.
2. Elektrický konektor / Elektroventil regulace stlačeného vzduchu.
3. Elektrický konektor / Vyhřívání čerpadla AdBlue/DEF.
4. Vstup kapaliny AdBlue/DEF.
5. Výstup aerosolu kapalina/vzduch
6. Odtok zpětného potrubí do nádrže.

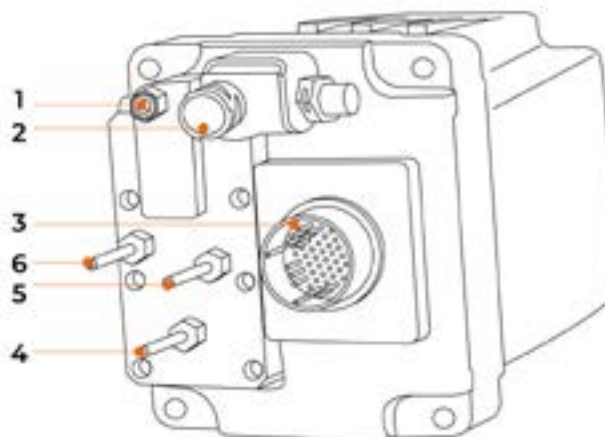

c. Připojte adaptéry “4” (4a nebo 4b podle potřeby) a “5” do sání stlačeného vzduchu modulu AdBlue/DEF (1) a do výstupu stlačeného vzduchu vozidla. Dále připojte hadici (“1” a “3”) do každého adaptéru, ale zatím bez připojení k nádrži “2a”.



d. Naplňte nádrž “2a” 250 ml horké destilované vody (MAX. 60°C/140°F) z horní části pomocí plnicí láhve “6”.



e. Připojte hadice “1” a “3” k nádrži “2a”

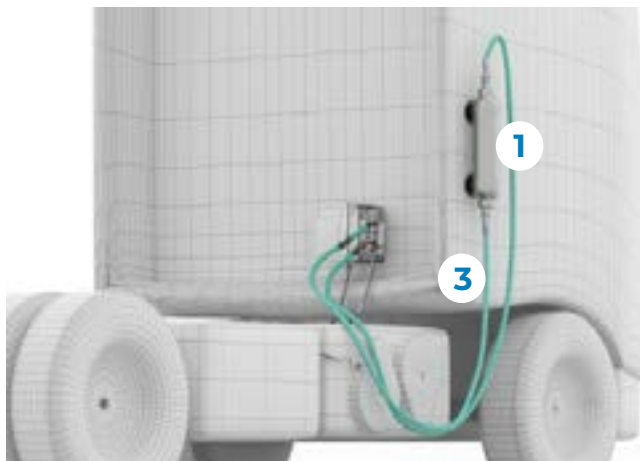



**f.** Nastartujte motor vozidla

**g.** Proveďte odpovídající činnost tolikrát, kolikrát je to nutné, pomocí diagnostického zařízení, dokud nebude tryskou vstřikovače vytlačován pouze stlačený vzduch. Použijte nádobu nebo odměrný válec k zachycení přibližně 250 ml vody, která bude vytlačena přes trysku vstřikovače.

### **Zapínání součástí >> “ELEKTROVENTIL DÁVKOVACÍHO ČERPADLA ADBLUE/DEF”**

**Poznámka:** v tomto případě slouží uvedená činnost pouze k zajištění řádného čištění okruhu AdBlue/DEF.

**h.** Znovu připojte všechny dříve odpojené prvky.

## 2.2.3 ČIŠTĚNÍ OKRUHU ADBLUE/DEF NA VSTUPU DO MODULU

**a.** Odpojte přívodní potrubí AdBlue/DEF od dávkovacího modulu **(4)**.

**b.** Odpojte zpětné potrubí kapaliny AdBlue/DEF **(6)**.

**c.** Umístěte nádobu nebo hadičku do trysky **(6)** abyste shromáždili množství vrácené kapaliny.

**d.** Připojte hadici **“7”** s rychlospojkou 3/8“ k sacímu portu AdBlue/DEF **(4)**.



**e.** Připojte hadici k nádrži **“2a”**.

Před tímto krokem musí být zásobník prázdný a bez hadic z předchozího testu.







- f. Naplňte nádrž “2a” 250 ml horké destilované vody (MAX. 60°C/140°F) z horní části.
- g. Nastartujte motor vozidla
- h. Proveďte odpovídající akci pomocí diagnostického nástroje a vyhodnoťte výsledek. Použijte nádobu nebo odměrný válec pro sběr vody, která bude dávkována tryskou. Pokud není všechna voda zcela vypuštěna, akci opakujte.

### Prověření systému >> “ČERPADLO ADBLUE/DEF”

**Poznámka:** v tomto případě slouží uvedená činnost pouze k zajištění řádného čištění okruhu AdBlue/DEF.

- i. Znovu připojte všechny dříve odpojené prvky.

## 2.2.4 NÁSLEDUJÍCÍ KROKY

- a. Zkontrolujte, že v řídicí jednotce nejsou uloženy žádné chyby.
- b. Demontujte zařízení na čištění modulu AdBlue/DEF a opláchněte všechny součásti horkou vodou, včetně nádrže.
- c. Připojte všechny spoje modulu AdBlue/DEF a zkontrolujte těsnost modulu i všech spojů.

## 2.3 ALBONAIR ADBLUE/DEF SYSTÉM

### 2.3.1 PREDCHÁDZAJÚCE KROKY

- a. Vykonajte test na prečistenie AdBlue/DEF okruhu pomocou diagnostického zariadenia.

### System ACM >> Preverenie systému >> “VYPUSTENIE OKRUHU SYSTÉMU ADBLUE/DEF”

- b. Demontujte ochranné kryty.





Pre vyšší komfort počas procesu čistenia, demontujte taktiež podperu bočného krytu.



**c.** Demontujte uchytenie vstrekovača AdBlue/DEF a následne vstrekovač vyberte.



**d.** Pod vstrekovaciú trysku umiestnite odmernú nádobu.



## 2.3.2 ČISTENIE OKRUHU ADBLUE/DEF

a. Demontujte prípojku prívodu AdBlue/DEF do modulu (3).

**Poznámka:** Vyčistite zvyšky AdBlue/DEF, ktoré by mohli po odpojení odpadnúť.

- A. Čerpadlo AdBlue/DEF.
- B. Vykurovací ventil AdBlue/DEF nádrže.
- C. Senzor teploty AdBlue/DEF / Vzduchový regulačný ventil.
- D. Senzor tlaku vzduchu.
- E. Senzor tlaku AdBlue/DEF.

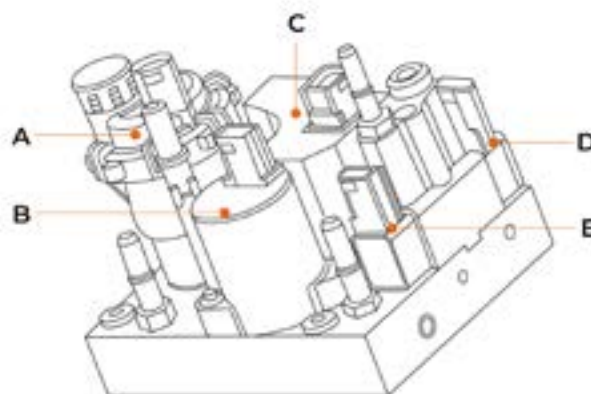

- 1. Prívod chladiacej kvapaliny.
- 2. Prívod stlačeného vzduchu.
- 3. Prívod AdBlue/DEF.

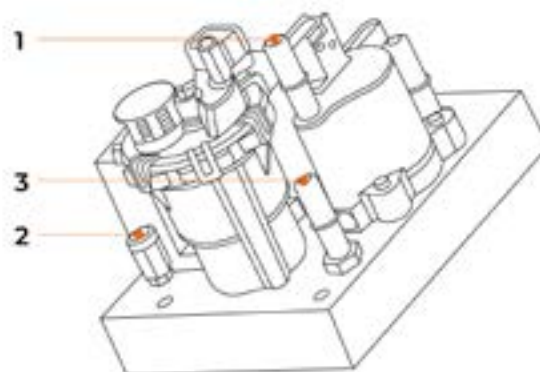

- 4. Výstup chladiacej kvapaliny.
- 5. Výstup vzduchu.
- 6. Výstup AdBlue/DEF.

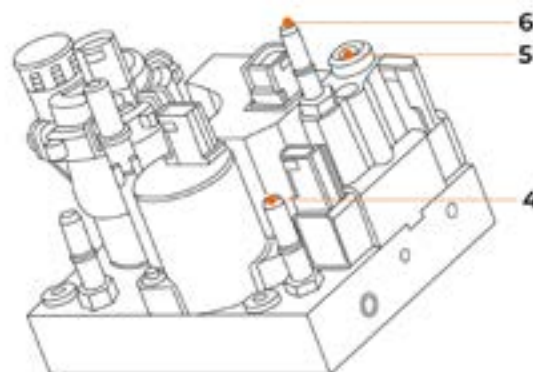



**b.** Pripojte hadicu “7” s rýchlospjkou 3/8” k prípojke prívodu AdBlue/DEF (3).



**c.** Druhý koniec hadice “7” pripojte k rýchlospjke na dne nádrže “2a”.

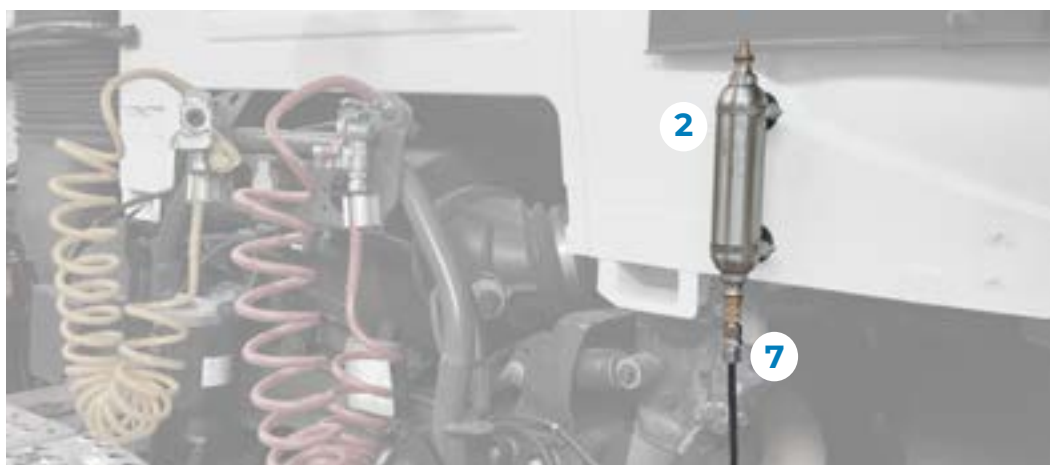

**d.** Pomocou plniacej fľaše “6” naplňte z vrchu nádrž “2a” s približne 200ml horúcej destilovanej vody (MAX. 60 °C/140 °F).





e. Vykonajte kontrolu čistenia modulu AdBlue/DEF pomocou diagnostického zariadenia.

### **System ACM >> Preverenie systému >> "ČISTENIE ADBLUE/DEF MODULU"**

**Poznámka:** Aby sa zabezpečilo, že okruh AdBlue/DEF nie je upchatý a systém funguje správne, musí sa dávkovaný objem vody pohybovať medzi maximálnou a minimálnou hodnotou uvedenou na konci testu.

## 2.3.3 NASLEDUJÚCE KROKY

- a. Skontrolujte, či v riadiacej jednotke nie sú zapamätané žiadne chyby.
- b. Odpojte diagnostické zariadenie a vypnite zapalovanie vozidla.
- c. Rozmontujte vybavenie na čistenie Adblue/DEF modulu a opláchnite všetky komponenty vrátane nádrže horúcou vodou.
- d. Namontujte prípojky AdBlue/DEF modulu a skontrolujte celkové utesnenie modulu vrátane prípojok.
- e. Namontujte vstrekovač AdBlue/DEF.
- f. Namontujte ochranné kryty.

## 2.4 BOSCH DENOXTRONIC 2.2 A DENOXTRONIC 6-HD ADBLUE/DEF SYSTÉM

### 2.4.1 ÚVODNÍ KROKY

- a. Vykonajte preplach okruhu AdBlue/DEF.

**Poznámka:** Vypnite zapalovanie a pred opätovným zapnutím počkajte 2 minúty.



**b.** Nájdite dávkovací modul AdBlue/DEF.

**Poznámka:** Umiestnenie závisí od typu vozidla.

**c.** V prípade potreby demontujte ochranné kryty.

**d.** Demontujte upevnenie vstrekoča AdBlue/DEF a vyberte vstrekoča.

**Poznámka:** Umiestnenie závisí od typu vozidla.



**e.** Pod vstrekovaciu trysku umiestnite nádobu.

## 2.4.2 ČISTENIE OKRUHU ADBLUE/DEF

**a.** Odpojte prírodné potrubie AdBlue/DEF od dávkovacieho modulu **(6)**.

**Poznámka:** Vyčistite zvyšky AdBlue/DEF, ktoré by mohli spadnúť počas odpájania.

**b.** Odpojte potrubie spätného toku kvapaliny AdBlue/DEF do nádrže **(4)**.

- 1.** Výstup AdBlue/DEF.
- 2.** Výstup chladiacej kvapaliny.
- 3.** Prívod chladiacej kvapaliny.
- 4.** Spätné potrubie AdBlue/DEF.
- 5.** Elektrický konektor.
- 6.** Výstup AdBlue/DEF.

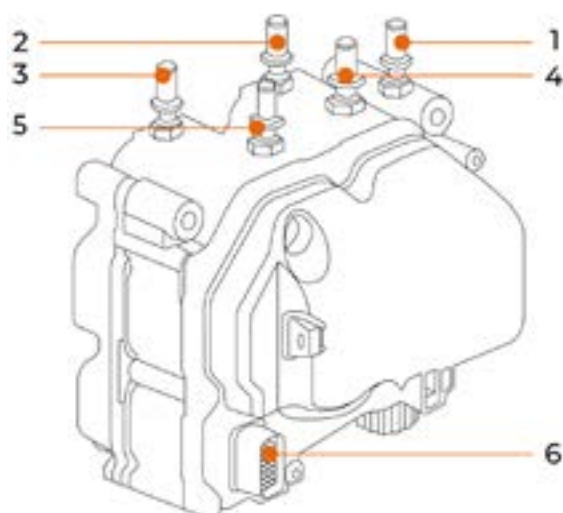

- c. Pripojte hadicu “7” s rýchlospojkou 3/8” k prípojke vstupu AdBlue/DEF (6).
- d. Pripojte adaptér “8” ku konektoru spätného vedenia AdBlue/DEF (4) a na voľný koniec umiestnite nádobu.

**Poznámka:** Počas testu a v závislosti od vozidla môže byť množstvo dávkovanej vody približne do 700 ml.

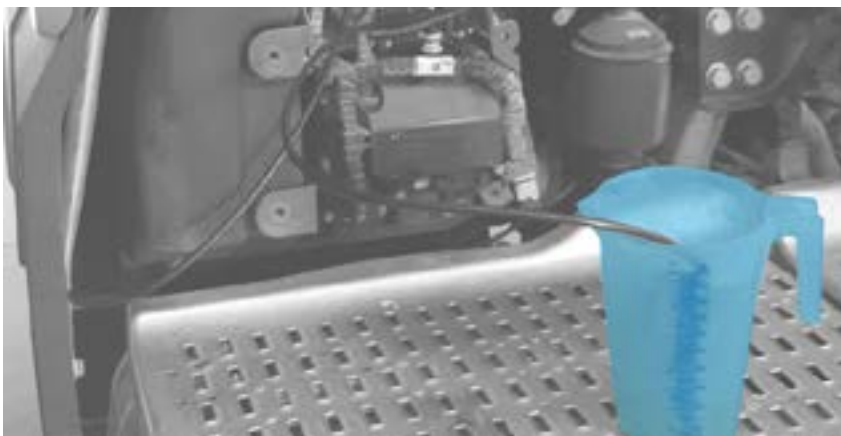

- e. Druhý koniec hadice “7” pripojte k rýchlospojke na spodku nádrže “2b”.

**Poznámka:** Nádrž umiestnite do výšky nad vstupný otvor dávkovacieho modulu AdBlue/DEF.



- f. Pomocou plniacej fľaše “6” naplňte nádrž “2b” z hornej strany horúcou destilovanou vodou (max. 60 °C/140 °F).



**g.** Vykonajte akciu prečistenia modulu AdBlue/DEF pomocou diagnostického nástroja.

### Údržba >> "ČISTENIE MODULU ADBLUE/DEF"

**Poznámka:** Aby sa zabezpečilo, že okruh AdBlue/DEF nie je upchatý a systém funguje správne, musí sa dávkovaný objem vody pohybovať medzi maximálnymi a minimálnymi hodnotami uvedenými na konci akcie.

## 2.4.3 NÁSLEDUJÍCÍ KROKY

- a.** Skontrolujte, či sa v riadiacej jednotke nenachádzajú žiadne zapamätané chyby.
- b.** Odpojte hadicu "7" zo spodnej časti nádrže "2b".
- c.** Odpojte diagnostické zariadenie a vypnite zapalovanie vozidla.

**Dôležité:** V ďalšom kroku pre pokračovanie, musí systém automaticky vypustiť zvyšnú vodu z potrubia.

- d.** Rozmontujte zariadenie na čistenie modulu AdBlue/DEF a opláchnite všetky komponenty horúcou vodou vrátane nádrže.
- e.** Zostavte všetky komponenty rozobraté v predchádzajúcich krokoch.



# cojali

Jaltest.com  
cojali.com

2023 V.1 CZ



Local Distributor



**Набор для очистки модуля  
дозирования AdBlue/DEF**

Руководство пользователя

[jaltest.com](http://jaltest.com)

**cojali**  
INNOVATION & TECHNOLOGY



Rev. 01



## Набор для очистки модуля дозирования AdBlue/DEF

Руководство пользователя

**cojali**

INNOVATION & TECHNOLOGY



# Содержание

Содержание	3
Общая информация	4
1.1 ОПИСАНИЕ НАБОРА	4
1.2 СОСТАВ НАБОРА	4
1.3 ПРИМЕНЯЕМОСТЬ	4
1.4 МЕРЫ ПРЕДОСТОРОЖНОСТИ	5
Процедуры	6
2.1 СИСТЕМА ADBLUE/DEF EMITEC (NONOX)	6
2.1.1 ПРЕДВАРИТЕЛЬНЫЕ ШАГИ	6
2.1.2 ОЧИСТКА ВЫХОДНОГО КОНТУРА ADBLUE/DEF	7
2.1.3 ОЧИСТКА ВХОДНОГО КОНТУРА ПОДАЧИ ADBLUE/DEF В МОДУЛЬ	9
2.1.4 ПОСЛЕДУЮЩИЕ ШАГИ	10
2.2 СИСТЕМА ADBLUE/DEF EMITEC (ДВИГАТЕЛИ CUMMINS)	11
2.2.1 ПРЕДВАРИТЕЛЬНЫЕ ШАГИ	11
2.2.2 ОЧИСТКА ВЫХОДНОГО КОНТУРА ADBLUE/DEF	11
2.2.3 ОЧИСТКА ВХОДНОГО КОНТУРА ПОДАЧИ ADBLUE/DEF В МОДУЛЬ	13
2.2.4 ПОСЛЕДУЮЩИЕ ШАГИ	14
2.4 СИСТЕМА BOSCH DENOXTRONIC 2.2 И DENOXTRONIC 6-HD ADBLUE/DEF	18
2.4.1 ПРЕДВАРИТЕЛЬНЫЕ ШАГИ	18
2.4.2 ОЧИСТКА КОНТУРА ADBLUE/DEF	19
2.4.3 ПОСЛЕДУЮЩИЕ ШАГИ	21

## Удобная навигация



назад    содержание    вперёд



Перейдите  
быстро к  
необходимому  
разделу нажав  
на него

# 1 Общая информация

## 1.1 ОПИСАНИЕ НАБОРА

Набор оборудования для очистки от кристаллизованных остатков смеси AdBlue/DEF в дозирующем модуле, магистрали впрыска и в клапане впрыска.

## 1.2 СОСТАВ НАБОРА

**1.3.** Шланг.

**2a.** Бак 0,4л.

**2b.** Бак 1,5л.

**4.** Адаптер для подключения к порту подачи сжатого воздуха в модуль AdBlue/DEF (4a и 4b).

**5.** Адаптер для подключения к подводу сжатого воздуха от транспортного средства к модулю AdBlue/DEF.

**6.** Заправочная ёмкость.

**7.** Адаптер для подключения к порту подачи смеси AdBlue/DEF в модуль.

**8.** Адаптер для возврата AdBlue/DEF в модуль.

**9.** Адаптеры 3/8" для подсоединения впускного и обратного патрубков к баку AdBlue/DEF.

**10.** Адаптеры 5/16" для подсоединения впускного и обратного патрубков к баку AdBlue/DEF.

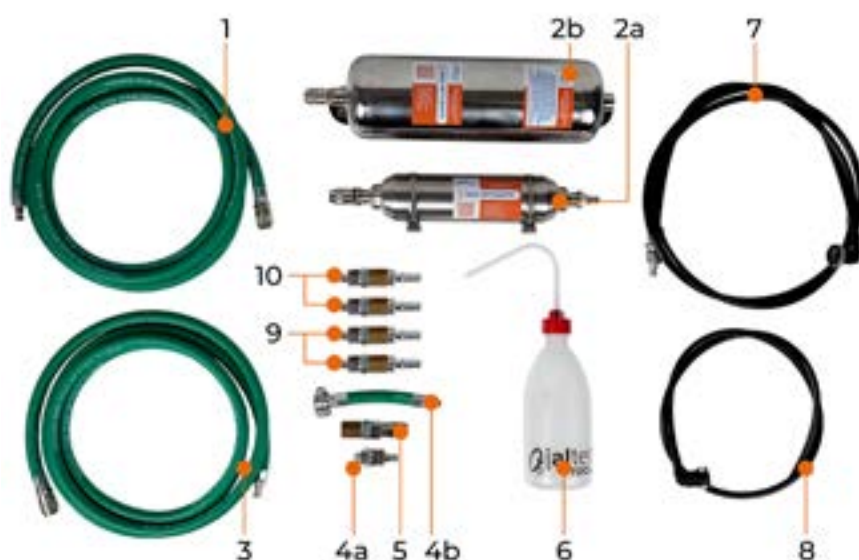

## 1.3 ПРИМЕНЯЕМОСТЬ

- Система снижения токсичности NoNOX (MAN TGL, TGM, TGS, TGX и автобусы Euro 6 с системой AdBlue Emitec).
- Система AdBlue/DEF Emitec для транспортных средств с двигателем Cummins.
- Система Albonair AdBlue/DEF (грузовики VOLVO, RENAULT UD и другие транспортные средства Euro 6).
- Системы Bosch Denoxtronic 2.2 и Denoxtronic 6-HD AdBlue/DEF (DAF, IVECO, MAN, другие транспортные средства Euro 6, сельскохозяйственная техника, спецтехника OHW и т.д.).

## 1.4 МЕРЫ ПРЕДОСТОРОЖНОСТИ

Во избежание несчастных случаев и/или травм необходимо соблюдать следующие меры предосторожности:

- Разместите транспортное средство на ровной поверхности.
- Активируйте стояночный тормоз.
- Установите рычаг переключения передач в нейтральное положение.
- Избегайте контакта с деталями, которые могут быть очень горячими или находятся в движении.
- Используйте соответствующую спецодежду.

## 2 Процедуры

### 2.1 СИСТЕМА ADBLUE/DEF EMITEC (NONOX)

#### 2.1.1 ПРЕДВАРИТЕЛЬНЫЕ ШАГИ

**a.** Выполните проверку слива из контура AdBlue/DEF с помощью диагностического прибора.

**Система NoNOx >> Проверки системы “ЗАПОЛНЕНИЕ И ПРОКАЧКА СИСТЕМЫ”**

**b.** Демонтируйте защитные пластины: верхнюю, переднюю и боковую.



**c.** Демонтируйте кронштейны крепления пластин.



**d.** Демонтируйте крепление инжектора AdBlue/DEF и снимите инжектор.

- Снимите хомут.
- Открутите крепёжную гайку.
- Демонтируйте инжектор AdBlue/DEF и прикрутите к нему крепёжную гайку.
- Очистите распылитель инжектора AdBlue/DEF.

**Примечание:** для удобства выполнения следующих шагов демонтируйте крепления датчика NOx.



**e.** Демонтируйте защитный кожух модуля AdBlue/DEF.



## 2.1.2 ОЧИСТКА ВЫХОДНОГО КОНТУРА ADBLUE/DEF

**a.** Сбросьте давление подачи пневматического питания для удобства при отсоединении и демонтажа магистралей, по которым проходит сжатый воздух.

**b.** Отсоедините разъём подачи сжатого воздуха к модулю AdBlue/DEF **(1)**.

**Примечание:** если в контуре питания транспортного средства присутствует сжатый воздух, при отключении этого соединения сжатый воздух покинет систему.





1. Вход сжатого воздуха.
2. Электрический разъём/клапан управления потоком сжатого воздуха.
3. Электрический разъём/подогреватель насоса AdBlue/DEF.
4. Вход AdBlue/DEF.
5. AdBlue/DEF и смеситель обработавших газов/смеси.
6. Обратный слив AdBlue/DEF.

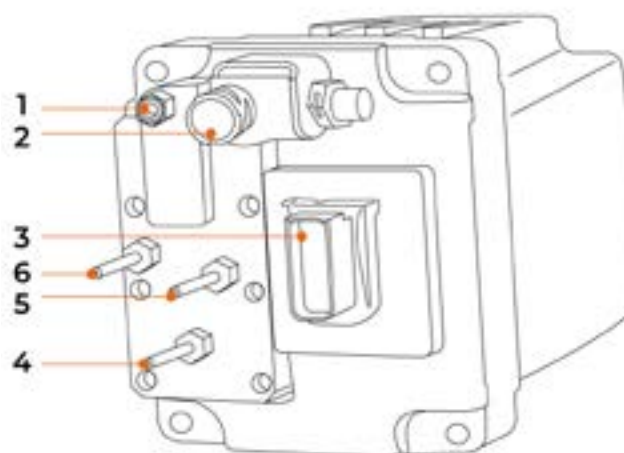

**с.** Подключите адаптеры **“4”** (**4a** или **4b** в зависимости от ситуации) и **“5”** к впускному разъёму сжатого воздуха модуля AdBlue/DEF (**1**) и к выпускному разъёму сжатого воздуха транспортного средства. Затем присоедините шланг (**“1”** и **“3”**) к каждому адаптеру, но при этом, не подсоединяя их к ёмкости **“2a”**.

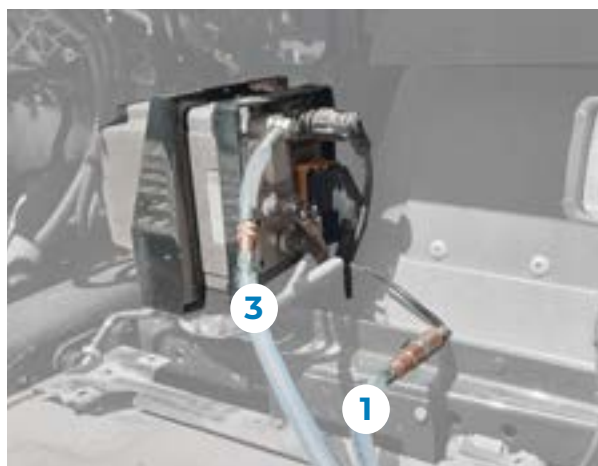

**d.** Заполните резервуар **“2a”** на 250 мл горячей дистиллированной водой (МАХ. 60°C/140°F) через верхнюю часть, используя заправочную ёмкость **“6”**.





**е.** Подключите шланги “1” и “3” к ёмкости “2а”.



**ф.** Запустите двигатель и поддерживайте его работу до тех пор, пока контур системы сжатого воздуха не будет заполнен.

**г.** Используя диагностическое оборудование, выполните соответствующую активацию столько раз, сколько необходимо, пока через сопло распылителя инжектора не будет выходить только сжатый воздух. Используйте контейнер или мерную ёмкость, чтобы собрать примерно 250 мл воды, которая будет вытеснена через инжектор.

### **Система NoNOx >> Проверки системы “ПРОВЕРКА КОНТУРА СЖАТОГО ВОЗДУХА”**

**h.** Перед выполнением тестов, снова выполните установку пневматических соединений. Подключите разъём (1) входа сжатого воздуха к модулю AdBlue/DEF.

**Примечание:** если в пневматическом контуре транспортного средства присутствует сжатый воздух, при отключении этого соединения сжатый воздух покинет систему.

## 2.1.3 ОЧИСТКА ВХОДНОГО КОНТУРА ПОДАЧИ ADBLUE/DEF В МОДУЛЬ

**a.** Запустите двигатель и поддерживайте его работу до тех пор, пока контур системы сжатого воздуха не будет заполнен.

**b.** Отключите соединения (4) и (6) от модуля AdBlue/DEF.

**c.** Установите ёмкость или наденьте трубку на сопло распылителя (6) для сбора сливаемой жидкости.

**d.** Подключите шланг “7” с быстроразъёмным соединением 3/8 к впускному патрубку AdBlue/DEF (4). Другой конец подсоедините к быстроразъёмному соединению на дне ёмкости “2а”.

Предварительно, резервуар должен быть пустой и с отключенными шлангами, которые использовались при предыдущей операции.

**е.** Заполнить резервуар “2а” дистиллированной водой через верхнюю часть (МАХ. 60°C/140°F). Имейте в виду, что объём заправки будет примерно такой же, как дозируемый.

**f.** Запустить тест среднего дозирования. Используйте контейнер или мерную ёмкость для сбора дозируемой через инжектор воды.

### Система NoNOx >> Проверки системы >> ДОЗИРОВАНИЕ ADBLUE/DEF>> “СРЕДНЕЕ ДОЗИРОВАНИЕ”



## 2.1.4 ПОСЛЕДУЮЩИЕ ШАГИ

- a.** Убедитесь, что в памяти блока управления отсутствуют сохранённые коды ошибок.
- b.** Демонтируйте использованное оборудование для очистки модуля AdBlue/DEF и промойте все компоненты, включая бак, горячей водой.
- c.** Установите разъёмы подключения модуля AdBlue/DEF и проверьте герметичность как самого модуля, так и соединений.
- d.** Установите защитный кожух модуля AdBlue/DEF.
- e.** Установите защитные пластины.



## 2.2 СИСТЕМА ADBLUE/DEF EMITEC (ДВИГАТЕЛИ CUMMINS)

### 2.2.1 ПРЕДВАРИТЕЛЬНЫЕ ШАГИ

- a. Выполните проверку дозирования присадки AdBlue/DEF
- b. Выключите зажигание и отсоедините клеммы аккумуляторных батарей
- c. Выполните сброс давления из системы дозирования AdBlue/DEF
- d. Демонтируйте инжектор AdBlue/DEF

**Примечание:** используйте подходящую ёмкость для установки под трубку



### 2.2.2 ОЧИСТКА ВЫХОДНОГО КОНТУРА ADBLUE/DEF

- a. Отсоедините трубку обратного слива AdBlue/DEF **(6)**
- b. Отсоедините трубку магистрали подачи воздуха модуля дозирования AdBlue/DEF **(1)**

1. Вход сжатого воздуха.
2. Электрический разъём/клапан управления потоком сжатого воздуха.
3. Электрический разъём/подогреватель насоса AdBlue/DEF.
4. Вход AdBlue/DEF.
5. AdBlue/DEF и смеситель отработавших газов/смеси.
6. Обратный слив AdBlue/DEF.

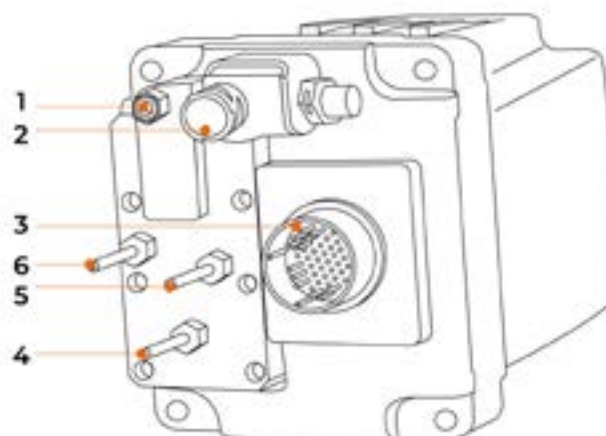



**с.** Подключите адаптеры **“4”** (**4a** или **4b** в зависимости от ситуации) и **“5”** к впускному разъёму сжатого воздуха модуля AdBlue/DEF **(1)** и к выпускному разъёму сжатого воздуха транспортного средства. Затем присоедините шланг **(“1”** и **“3”**) к каждому адаптеру, но при этом, не подсоединяя их к ёмкости **“2a”**.



**d.** Заполните резервуар **“2a”** на 250 мл горячей дистиллированной водой (МАХ. 60°C/140°F) через верхнюю часть, используя заправочную ёмкость **“6”**.



**e.** Подключите шланги **“1”** и **“3”** к ёмкости **“2a”**

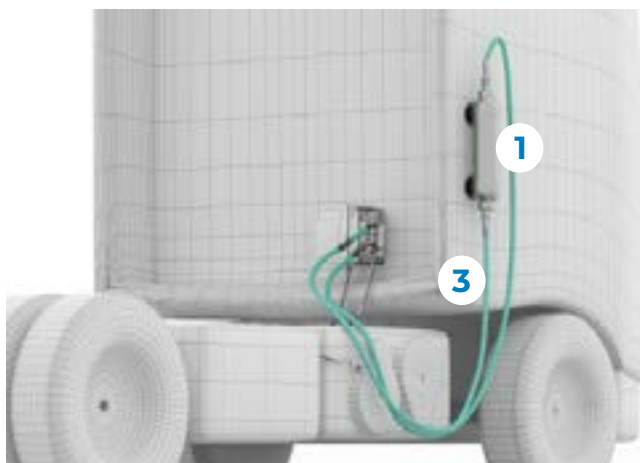



**f.** Запустите двигатель

**g.** Используя диагностическое оборудование, выполните соответствующую активацию столько раз, сколько необходимо, пока через сопло распылителя инжектора не будет выходить только сжатый воздух. Используйте контейнер или мерную ёмкость, чтобы собрать примерно 250 мл воды, которая будет вытеснена через инжектор.

### **Активация компонентов >> “ЭЛЕКТРОМАГНИТНЫЙ КЛАПАН НАСОСА ДОЗИРОВАНИЯ ADBLUE/DEF”**

**Примечание:** указанные действия выполняются только для выполнения качественной очистки контура AdBlue/DEF.

**h.** Подключите обратно ранее отсоединённые элементы.

## 2.2.3 ОЧИСТКА ВХОДНОГО КОНТУРА ПОДАЧИ ADBLUE/DEF В МОДУЛЬ

**a.** Отсоедините трубку магистрали подачи воздуха от модуля дозирования AdBlue/DEF **(4)**.

**b.** Отсоедините трубку обратного слива AdBlue/DEF **(6)**.

**c.** Установите ёмкость или наденьте трубку на сопло распылителя **(6)** для сбора сливаемой жидкости.

**d.** Подключите шланг **“7”** с быстроразъёмным соединением 3/8 к впускному патрубку AdBlue/DEF **(4)**.

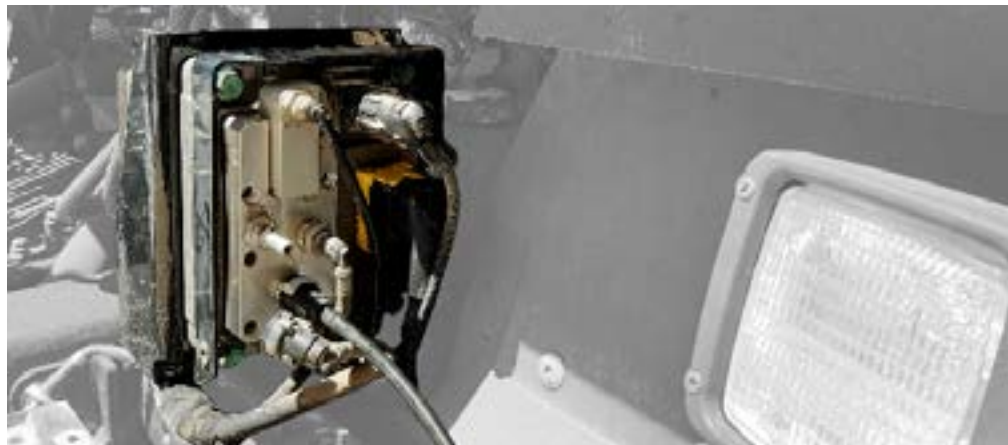

**e.** Подключите шланг к ёмкости **“2a”**.

Предварительно, резервуар должен быть пустой и с отключенными шлангами, которые использовались при предыдущей операции.





**f.** Заполните резервуар **“2a”** на 250 мл горячей дистиллированной водой (МАХ. 60°C/140°F) через верхнюю часть.

**g.** Запустите двигатель

**h.** Выполните необходимое действие с применением диагностического оборудования до достижения результата. Используйте ёмкость или мерный контейнер для сбора воды, проходящей через инжектор. Если вода не сливается из инжектора полностью, процедуру необходимо повторить.

### Проверки системы >> “НАСОС ADBLUE/DEF”

**Примечание:** указанные действия выполняются только для выполнения качественной очистки контура AdBlue/DEF.

**i.** Подключите обратно ранее отсоединённые элементы.

## 2.2.4 ПОСЛЕДУЮЩИЕ ШАГИ

**a.** Убедитесь, что в памяти блока управления отсутствуют сохранённые коды ошибок.

**b.** Демонтируйте использованное оборудование для очистки модуля AdBlue/DEF и промойте все компоненты, включая бак, горячей водой.

**c.** Установите разъёмы подключения модуля AdBlue/DEF и проверьте герметичность как самого модуля, так и соединений.

## 2.3 СИСТЕМА ADBLUE ALBONAIR

### 2.3.1 ПРЕДВАРИТЕЛЬНЫЕ ШАГИ

**a.** Выполните тест прокачки контура AdBlue/DEF с помощью диагностического оборудования.

### Система ACM >> Проверки системы >> “ПРОКАЧКА КОНТУРА ADBLUE/DEF”

**b.** Демонтируйте защитные пластины.



Для большего удобства при выполнении процесса, также снимите кронштейн боковой пластины.



**c.** Демонтируйте крепление инжектора AdBlue/DEF и снимите инжектор.



**d.** Установите ёмкость под распылителем инжектора.





## 2.3.2 ОЧИСТКА КОНТУРА ADBLUE/DEF

**a.** Отсоедините разъем подачи к модулю AdBlue/DEF **(3)**.

**Примечание:** Очистите остатки AdBlue/DEF, которые могут протечь после использования оборудования.

- A.** Насос AdBlue/DEF.
- B.** Клапан нагрева бака AdBlue/DEF. (Diesel Exhaust Fluid).
- C.** Датчик температуры AdBlue / Клапан регулировки воздуха.
- D.** Датчик давления воздуха.
- E.** Датчик давления AdBlue/DEF. (Diesel Exhaust Fluid)

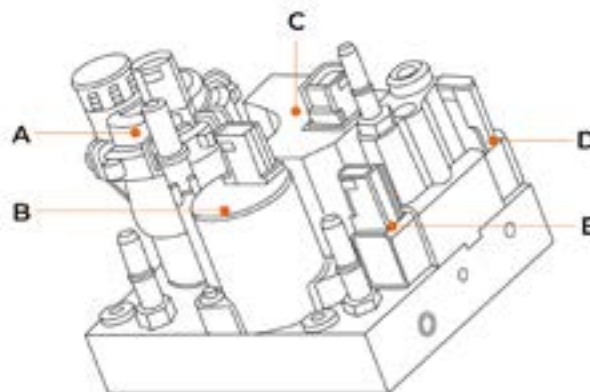

- 1.** Вход охлаждающей жидкости.
- 2.** Вход сжатого воздуха.
- 3.** Вход AdBlue/DEF.

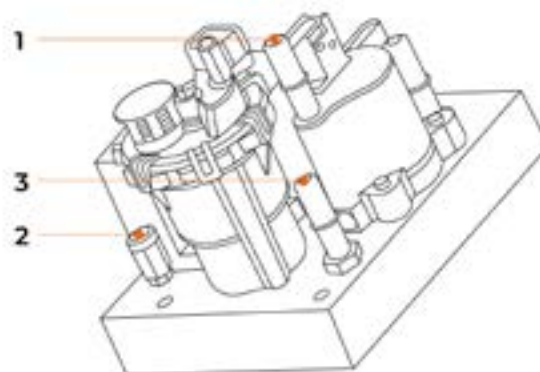

- 4.** Выход охлаждающей жидкости.
- 5.** Выход сжатого воздуха.
- 6.** Выход AdBlue/DEF.

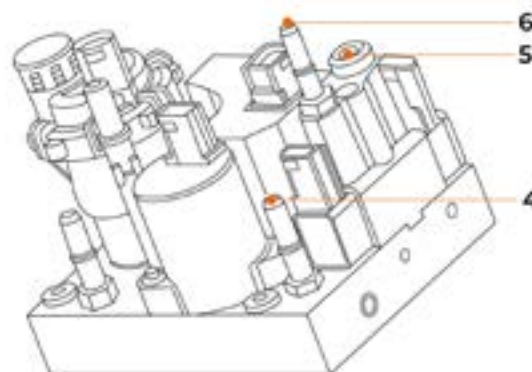



**b.** Подключите шланг “7” с быстроразъёмным соединением 3/8 к впускному патрубку AdBlue/DEF (3). (3).



**c.** Подключите другой конец шланга “7” с быстроразъёмным соединением к верхней части резервуара “2a”.

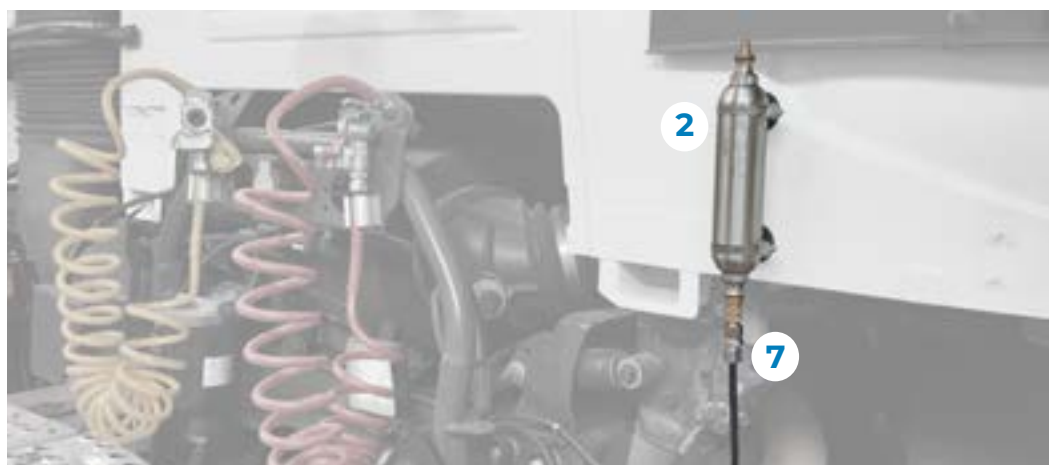

**d.** Заполните резервуар “2a” на 250 мл горячей дистиллированной водой (МАХ. 60°C/140°F) через верхнюю часть, используя заправочную ёмкость “6”.





**e.** Выполните тест для очистки модуля AdBlue/DEF с помощью диагностического оборудования.

### **Система АСМ >> Проверки системы >> “ОЧИСТКА МОДУЛЯ ADBLUE/DEF”**

**Примечание:** Чтобы убедиться, что контур AdBlue/DEF не имеет загрязнений и система работает правильно, дозируемый объем воды должен находиться между максимальным и минимальным значениями, указанными в конце активации.

## 2.3.3 ПОСЛЕДУЮЩИЕ ШАГИ

- a.** Убедитесь, что в памяти блока управления отсутствуют сохранённые коды ошибок.
- b.** Отсоедините диагностическое оборудование и выключите зажигание транспортного средства.
- c.** Демонтируйте использованное оборудование для очистки модуля AdBlue/DEF и промойте все компоненты, включая резервуар, горячей водой.
- d.** Установите разъёмы подключения модуля AdBlue/DEF и проверьте герметичность как самого модуля, так и соединений.
- e.** Установите инжектор AdBlue/DEF.
- f.** Установите защитные пластины.

## 2.4 СИСТЕМА BOSCH DENOXTRONIC 2.2 И DENOX-TRONIC 6-HD ADBLUE/DEF

### 2.4.1 ПРЕДВАРИТЕЛЬНЫЕ ШАГИ

- a.** Выполните прокачку контура AdBlue/DEF.

**Примечание:** Выключите зажигание и подождите 2 минуты, прежде чем снова включить его.



**b.** Определите место, где установлен модуль дозирования AdBlue/DEF.

**Примечание:** Местоположение зависит от транспортного средства.

**c.** При необходимости демонтируйте защитные пластины.

**d.** Демонтируйте крепление инжектора AdBlue/DEF и снимите инжектор.

**Примечание:** Местоположение зависит от транспортного средства.



**e.** Поместите ёмкость под инжектор.

## 2.4.2 ОЧИСТКА КОНТУРА ADBLUE/DEF

**a.** Отсоедините подводящий патрубок AdBlue/DEF от дозирующего модуля **(6)**.

**Примечание:** Очистите поверхности от остатков AdBlue/DEF, которые могут протечь после использования оборудования.

**b.** Отсоедините возвратный патрубок жидкости AdBlue/DEF в бак **(4)**.

- 1.** Выход AdBlue/DEF.
- 2.** Выход охлаждающей жидкости.
- 3.** Вход охлаждающей жидкости.
- 4.** Возврат AdBlue/DEF.
- 5.** Электрический разъём.
- 6.** Вход AdBlue/DEF.

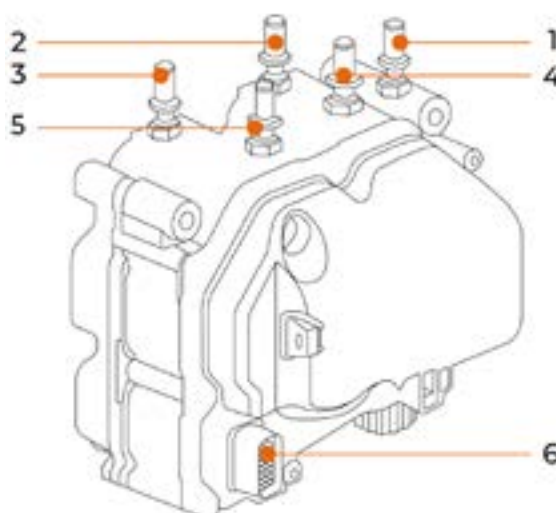

**c.** Подсоедините шланг “7” с быстроразъёмным соединением 3/8” к впускному разъёму AdBlue/DEF (6).

**d.** Подсоедините адаптер “8” к обратному разъёму AdBlue/DEF (4) и поместите свободный конец в ёмкость.

**Примечание:** Во время тестирования, в зависимости от транспортного средства, количество возвратной воды может составлять приблизительно до 700 мл.

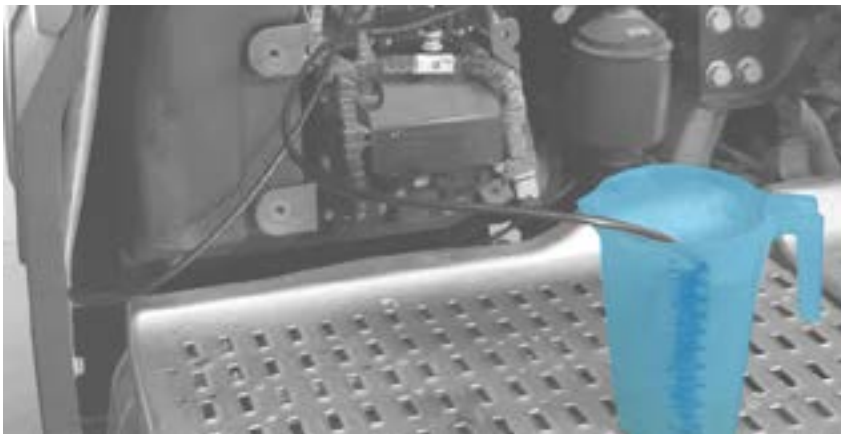

**e.** Подсоедините другой конец шланга “7” к быстроразъёмному соединению на дне бака “2b”.

**Примечание:** Установите бак на высоте над входным отверстием дозирующего модуля AdBlue/DEF.



**f.** Заполните бак “2b” горячей дистиллированной водой (не более 60°C/140°F) из верхней части, используя наполнительную бутылку “6”.



**g.** Выполните действие по очистке модуля AdBlue/DEF с помощью диагностического оборудования.

### **Техническое обслуживание >> “ОЧИСТКА МОДУЛЯ ADBLUE/DEF”**

**Примечание:** Чтобы убедиться, что контур AdBlue/DEF не засорен и система работает корректно, дозируемый объем воды должен находиться между максимальным и минимальным значениями, указанными в конце активации.

## 2.4.3 ПОСЛЕДУЮЩИЕ ШАГИ

**a.** Убедитесь, что в блоке управления не зафиксировано ошибок.

**b.** Отсоедините шланг “7” от нижней части бака “2b”.

**c.** Отсоедините диагностическое оборудование и выключите зажигание транспортного средства.

**Важно:** Прежде чем переходить к следующему шагу, система должна автоматически удалить оставшуюся воду из трубок.

**d.** Демонтируйте использованное оборудование для очистки модуля AdBlue/DEF и промойте все компоненты, включая резервуар, горячей водой.

**e.** Установите все компоненты, снятые на предыдущих этапах.

# ●.cojali

Jaltest.com  
cojali.com

2023 V.1 RU



Local Distributor